

# Digital Door Entry System

*CITADEL*

Installation Manual

In no event shall Planit Security Contracts Limited be liable to anyone for special, collateral, incidental or consequential damages in connection with or arising from purchase or use of these materials.

Planit Security Contracts Limited maintain a policy of active product improvement and development and reserve the right to revise the products on a continuous basis. This documentation describes the state of the product at the time of publication and may not reflect the product at all times in the future.

The contents of this document may not be reproduced either in part or as a whole for re-transmittal in any form either by physical or electronic means without prior approval of Planit Security Contracts Limited.

### **CE Declaration of Conformity**

We, Planit Security Contracts Limited, declare that the apparatus referred to within this handbook conforms with the protection requirements of Council Directive 89/336/EEC on the approximation of the laws of the Member States relating to electromagnetic compatibility when installed in strict accordance with the instructions contained herein.

### **Technical Support**

For all technical enquiries relating to the installation of the Citadel system and accessories,

Please telephone: **01268-548248**

Or fax your enquiry to us on: **01268-548257**

Alternatively Email your enquiry to us on: **info@planit-security.co.uk**

Please note: Enquiries can only be dealt with during normal working hours.

#### **You may write to us at:**

Planit Security Contracts Limited  
23 Saffron Court  
Southfields  
Laindon  
Essex  
SS15 6SS

<b>CONTENTS</b>	<b>PAGE</b>
<b>1. INTRODUCTION.....</b>	<b>4</b>
<b>2. SYSTEM OVERVIEW .....</b>	<b>4</b>
<b>3. SYSTEM COMPONENTS .....</b>	<b>4</b>
3.1 DECODER DD8153.....	4
3.2 ENTRANCE PANEL EP8154/.....	7
3.3 POWER SUPPLY ( STANDARD ) PU 8162.....	9
3.4 DWELLING HANDSET OPTIONS .....	11
<b>4. INSTALLATION .....</b>	<b>12</b>
4.1 INSTALLING THE CASES.....	12
4.2 INSTALLATION GUIDELINES.....	12
<b>5. WIRING THE SYSTEM.....</b>	<b>12</b>
5.1 GENERAL WIRING & CABLE REQUIREMENTS.....	12
5.2 WIRING OVERVIEW.....	13
5.2.1 <i>Data and Audio Cabling</i> .....	14
5.2.2 <i>Power Cabling</i> .....	14
5.2.3 <i>Earthing Requirements</i> .....	17
5.3 DATA CONNECTIONS .....	17
5.4 AUDIO CONNECTIONS .....	17
5.5 POWER SUPPLY CONNECTIONS .....	18
5.6 DWELLING HANDSETS .....	18
5.7 DOOR LOCK RELEASES.....	20
5.7.1 <i>Cable Information</i> .....	20
5.7.2 <i>Fail Safe (fail unlocked) Lock Release Connection</i> .....	20
5.8 PANEL AMPLIFIER.....	21
5.9 REQUEST TO EXIT SWITCHES (RTE).....	22
5.10 DOOR MONITORING CONTACTS .....	22
5.11 STROBE CONNECTION.....	22
5.12 BATTERY BACK UP.....	22
<b>6. HARDWARE CONFIGURATION .....</b>	<b>23</b>
6.1 SYSTEM ADDRESSING.....	23
6.2 DOOR TONE VOLUME CONTROLS .....	23
6.3 MICROPHONE & LOUDSPEAKER VOLUME CONTROL.....	23
6.4 PRIVACY FUNCTION TIMER.....	23
6.5 DISABLE LOCK RELEASE SENSING.....	24
6.6 FUNCTIONAL PANEL SELECTION .....	25
6.7 ALARMS .....	25
6.8 FIRE SWITCH.....	25

<b>7.</b>	<b>PROGRAMMING THE SYSTEM.....</b>	<b>26</b>
7.1	SOFTWARE CONFIGURATION OVERVIEW .....	26
7.2	SOFTWARE CONFIGURATION GUIDE.....	26
7.2.1	<i>Setting the Defaults</i> .....	26
7.2.2	<i>Gaining Access to the Configuration Program</i> .....	26
7.3	START UP MENU CODE LISTING.....	28
7.4	SOFTWARE CONFIGURATION INSTRUCTIONS .....	29
7.4.1	<i>Synchronisation Functions</i> .....	29
7.4.2	<i>Clear Functions</i> .....	29
7.4.3	<i>Individual Function Details</i> .....	30
7.5	PROGRAMMING DATA SHEET .....	35
<b>8.</b>	<b>ADVANCED PROGRAMMING FUNCTIONS.....</b>	<b>36</b>
8.1	ADVANCED PROGRAMMING FUNCTIONS OVERVIEW .....	36
8.2	ADVANCED MENU CODE LISTING .....	36
8.3	ADVANCED SOFTWARE CONFIGURATION INSTRUCTIONS.....	37
8.4	TEST FUNCTIONS .....	40
<b>9.</b>	<b>FAULT FINDING THE SYSTEM.....</b>	<b>40</b>
9.1	DATA NETWORK.....	40
9.2	AUDIO NETWORK .....	41
9.3	CALLING PROBLEMS .....	41
9.4	FUSES.....	42
<b>10.</b>	<b>APPENDIX 1 - FULL PROGRAMMING MENU LISTING.....</b>	<b>43</b>
<b>11.</b>	<b>APPENDIX 2 - SYSTEM DEFAULT SETTINGS.....</b>	<b>44</b>
<b>12.</b>	<b>APPENDIX 3 - ERROR MESSAGE DEFINITIONS .....</b>	<b>44</b>
<b>13.</b>	<b>APPENDIX 4 - DIL SWITCH SETTINGS.....</b>	<b>45</b>
<b>14.</b>	<b>APPENDIX 5 - TYPICAL LOCK RELEASE CURRENTS.....</b>	<b>45</b>
<b>15.</b>	<b>APPENDIX 6 - TYPICAL ENTRANCE PANEL KEYBOARD MATRIX INFORMATION.....</b>	<b>46</b>
<b>16.</b>	<b>APPENDIX 7 - SPECIFICATIONS.....</b>	<b>48</b>
16.1	SYSTEM .....	48
16.2	DIGITAL DECODER.....	48
16.3	ENTRANCE PANEL.....	48
16.4	POWER SUPPLY .....	49
16.5	TELEPHONE HANDSET.....	49
16.6	CITADEL RANGE ORDERING INFORMATION.....	51
<b>17.</b>	<b>APPENDIX 8 - GLOSSARY OF TERMS .....</b>	<b>52</b>
<b>18.</b>	<b>APPENDIX 9 - COMMISSIONING CHECK SHEET (AUDIO).....</b>	<b>55</b>
<b>19.</b>	<b>APPENDIX 10 - DOOR ENTRY TELEPHONE INSTRUCTION LEAFLET .....</b>	<b>56</b>

## 1. INTRODUCTION

This manual will assist in the successful installation of the Citadel range of controlled door entry systems. Please read carefully all the following sections prior to commencing installation. Planit Security Contracts Limited will not be liable for any damaged equipment caused by faulty installation where these instructions have not been complied with. Our terms and conditions of sale and guarantee apply in all instances.

## 2. SYSTEM OVERVIEW

The Citadel range is an advanced and cost effective digital door entry system that can also support functional panels. The system is designed for an easy installation to a high specification. The range consists of a digital decoder assembly, which supports up to 16 dwellings. Up to 16 decoders can be installed on any one system giving 256 dwellings. The decoder is housed in a strong metal case as standard, and can be supplied in alternative IP rated cases as required. The decoders can be mounted throughout the installation as dictated by site conditions, with a maximum total cable run of 800 metres.

Connection between the digital decoders, and to the entrance panels is via a 3 wire data link, a 3 wire audio link, and a 2 wire power supply connection.

The entrance panel contains the system controller and configuration information, along with a 20mm 4 digit 7 segment display. The entrance panel contains control electronics for a fireswitch, RTE, a trade clock and coded access facilities. The system can support multiple panels with busy indication as a message on the display.

The audio and data wiring to the entrance panel is the same as the decoder, and all devices are connected effectively in a daisy chain. A star wire distribution board can be supplied if required by local installation practice.

The entrance panel is supplied using custom highly vandal resistant individual buttons.

The standard power supply supplies 5 amps at 18 volts dc, which is adequate for most systems. It contains battery back up as standard, along with various monitor LEDs.

The telephone handsets are available with privacy, privacy status indication, duplex audio, lock release, electronic call tone and door monitor indication options.

## 3. SYSTEM COMPONENTS

### 3.1 Decoder DD8153

Max Number Dwellings	16
Line interface	RS485
Call in progress output	
Current Consumption	375mA (Without auxiliary current draw)
Full isolation of speech	

A 12 volt and 0v supply is provided when call is in progress. Note that this output is NOT isolated, and when used to connect to third party systems, a relay with back EMF diode must be used for isolation. Each dwelling connection is isolated and protected without using fuses. These design features greatly eases the problem of checking power distribution as if the voltage measured is correct at installation time, then you can be confident that it will remain in specification.

The dwelling interface consists of:

Audio Out

Audio In

Privacy LED drive ( Limited to 8mA )

Door Alarm LED drive ( Limited to 8mA )

Privacy Switch ( Opto Isolated )

0v

### *Line Interface*

The connection between the 8153 and the rest of the system consists of:

2 Power feed I/O connections, 15-18 volts DC.

3 Data wires ( RS485 ) consisting of two signal wires and an 0v reference (screened).

3 Audio wires comprising audio out, audio in, and an 0V reference.

### *Off Hook*

The decoder automatically detects the off hook condition and contains logic to be able to detect that a phone is connected.

### *Ring Tone*

The system can be programmed for individual ring levels and ring periods for each dwelling from the entrance panel. This is a configuration option, and for most installations the default setting of 75% of maximum will suffice.

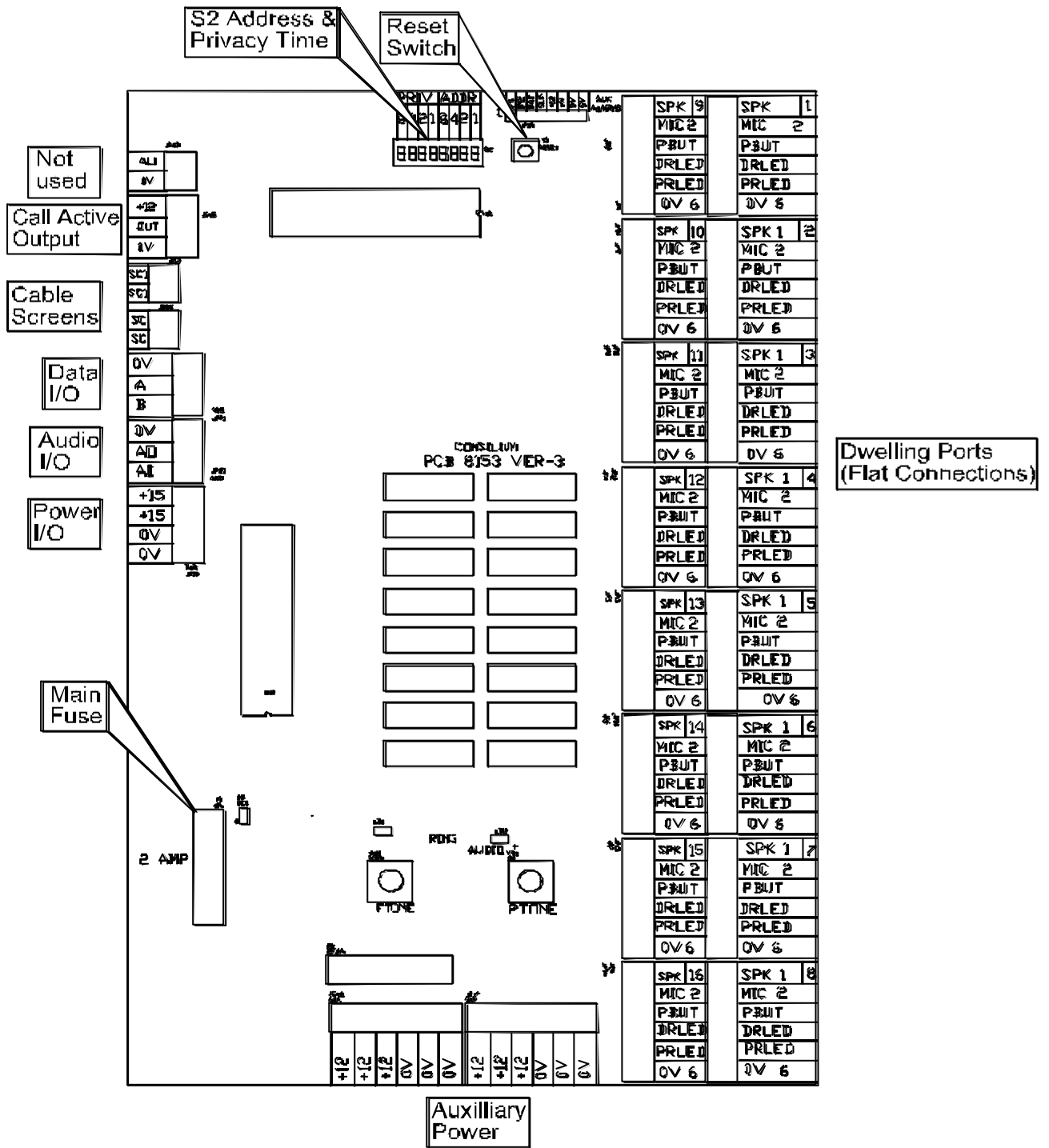

For Citadel Video refer to appendix 11

### *Confidence Tones*

A separate level control R25 "FTONE" is used to adjust ring confidence tones to the dwelling.

### *Screened Cable*

Where screened cable is used (see installation instructions) two connectors are provided SC and SC1 to enable the cable screens to be looped through tidily. They have no on board electrical connection.

### *Auxiliary Power*

Up to 500 mA is provided on the auxiliary 12Vdc power connector to allow the connection of strobes etc., within the apartments. If you anticipate installing strobes or additional sounders please ensure your system power supply rating is of a suitable capacity and that the power supply cables are correctly selected.

### *Switch Settings*

A DIP switch is provided to enable the board address to be set up, and the default privacy timer period to be set.

## **3.2 Entrance Panel EP8154/**

The Citadel range is of a distributed processing architecture design, and hence is not dependent on any one specific board for some form of functionality, with the exception of the power supply.

The entrance panel display board does however, contain most of the system configuration, and if any board can be considered the focus of the system, it is this board.

The entrance panel display board is normally fitted into the entrance panel, and is the origin of calls made on the system. It contains a micro processor, 2 sets of non-volatile memory, lock release control and lock power regulation, door monitoring and fire switch inputs, call in progress output, and an independently battery backed time and date clock.

It has a 4 banked 7 segment digital display.

The EP8154 also makes an excellent engineering test panel, and for contractors installing a number of these systems, would make a worthwhile investment as a system test and configuration aid.

The panel can also be fitted with a high resolution monochrome camera.

**For Citadel Video refer to appendix 11**

The EP8154 contains the system configuration for that particular panel, on multi panel systems each panel can contain a unique configuration, which greatly eases system design when multiple panels are installed, and where each panel has restricted calling, different locks, etc. Where there are multiple panels with identical configuration, it is only required to program 1 panel, and the system can be instructed to synchronise to that panel, i.e. all other panels will automatically adopt the configuration of the designated primary panel, see software guide for those functions with synchronisation facilities.

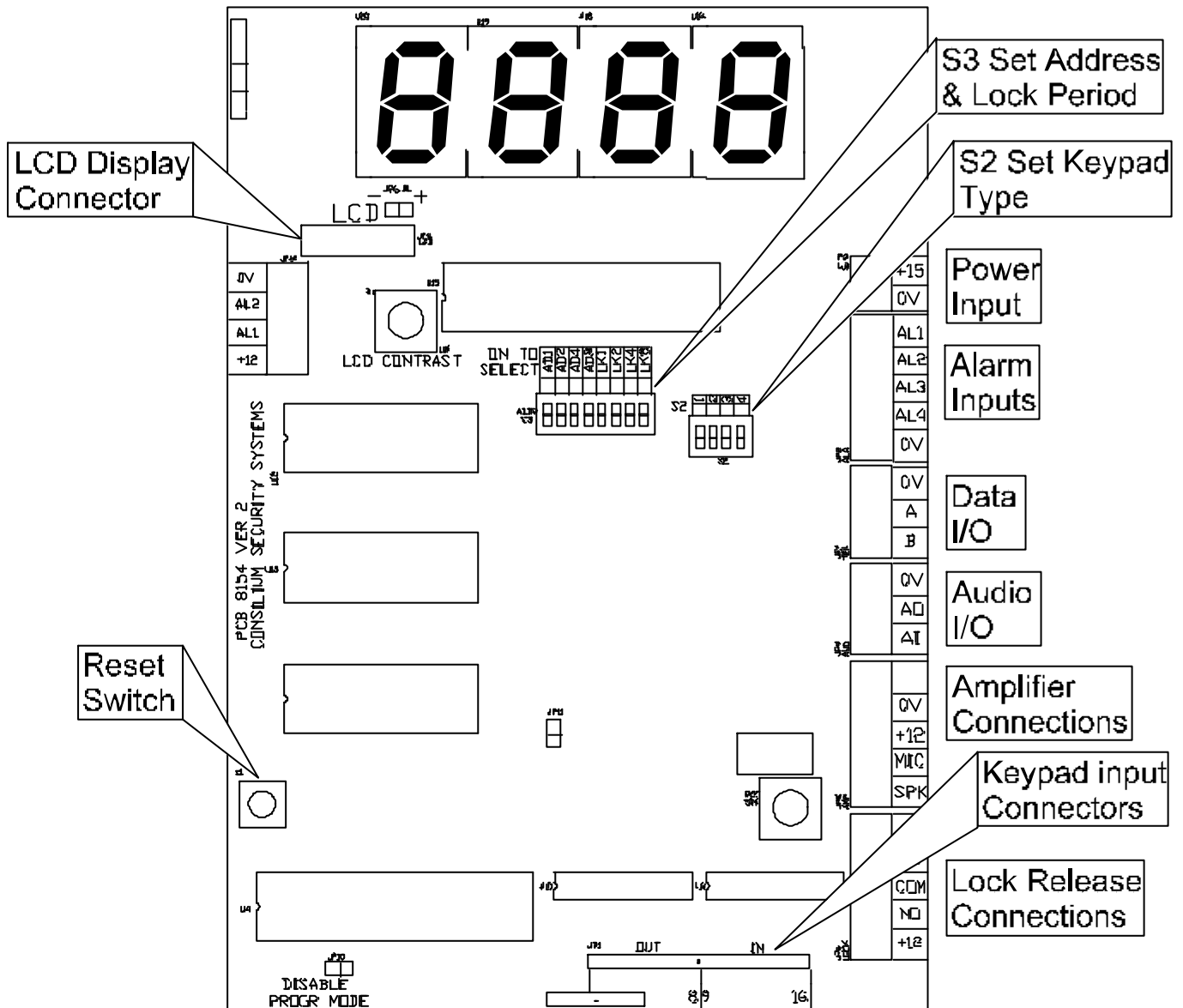

The lock power is derived from a built in regulator, and the lock control is via a relay with changeover contacts rated at 1 amp. Any locks connected to this relay MUST be fitted with protection diodes, 1 per lock, fitted at the lock. One of the most common causes of problems is lack of protection diodes, and lack of diodes can cause premature failure of the switching relay, and under some circumstances can cause corruption of the entrance panel memory.

The lock release timing is controlled locally from within the panel and can be programmed from 1-99 seconds, the system provides the facility to truncate the lock period upon door open and therefore reset the lock timer. The lock release electronics contain a special circuit for monitoring the lock power.

When the door requires an RTE switch (request to exit) this is simply wired in series with the lock power (or parallel with the control relay depending on the type of lock), the display board monitors the lock current change caused by the switch and generates an automatically timed lock release operation. Note that if it is required that the RTE switch reports an alarm condition to a concierge or similar, a separate contact must be wired on the RTE switch to the entrance panel controller.

An output is provided from the panel which is active low when a call is made, and clears to active high when the call is completed. This output is primarily designed for camera switching but can have other applications.

The door contact interacts with the lock release in that after the door has been legally opened (physically as detected by the door alarm contact) the lock release will automatically be re-locked. This feature can be disabled in the system configuration, and the default is that it is normally active.

Provision is made for monitoring the state of the fire alarm switch. To comply with fire regulations the fire switch must switch the lock directly using the switch built into the fire switch. By using a double pole switch in the fire switch, the second set of contacts from the fire switch can be wired to AL2 on the entrance panel. This alarm input can be programmed for either a normally open or normally closed contact.

When the fire switch is operated, the entrance panel will generate a timed lock release as defined in the system set-up parameters. This period would normally be about 20 seconds. The message fire will be displayed on the entrance panel, and again via the system configuration this message can be broadcast to all other panels on the system, which will also display the message FIRE.

When this message is broadcast to the other panels, they will automatically unlock their door for the fire switch period as programmed into EACH panel.

### 3.3 Power Supply ( Standard ) PU 8162

The power supply consists of a single PCB with built in rectifier, regulator and battery back up circuits. It is connected to a 22 volt AC centre tapped transformer and is normally supplied mounted in a steel case. The nominal output is +18 volts at 5 amps. The video power supply is the same but with video switcher and monitor power supply. **For Citadel Video refer to appendix 11**

The power supply has 4 outputs, each fused at 5 amps, with an output voltage of 18.00 +/-1 volt. Note that although each output is fused at 5 amps, the overall maximum for the power supply is 5 amps for all outputs, It is envisaged that for a 'standard' installation the decoders will be connected to 1 or more outputs, and the entrance panel(s) to the other outputs. Where possible each entrance panel should be connected to a separate output as this ensures maximum system integrity in the case of mechanical damage or vandalism to an individual panel which may cause a power short circuit.

Each output is fused as 5 amps and each output is provided with an output healthy green LED, which is normally illuminated. If a fuse fails, this LED will be extinguished, and the RED fuse fail LED will illuminate.

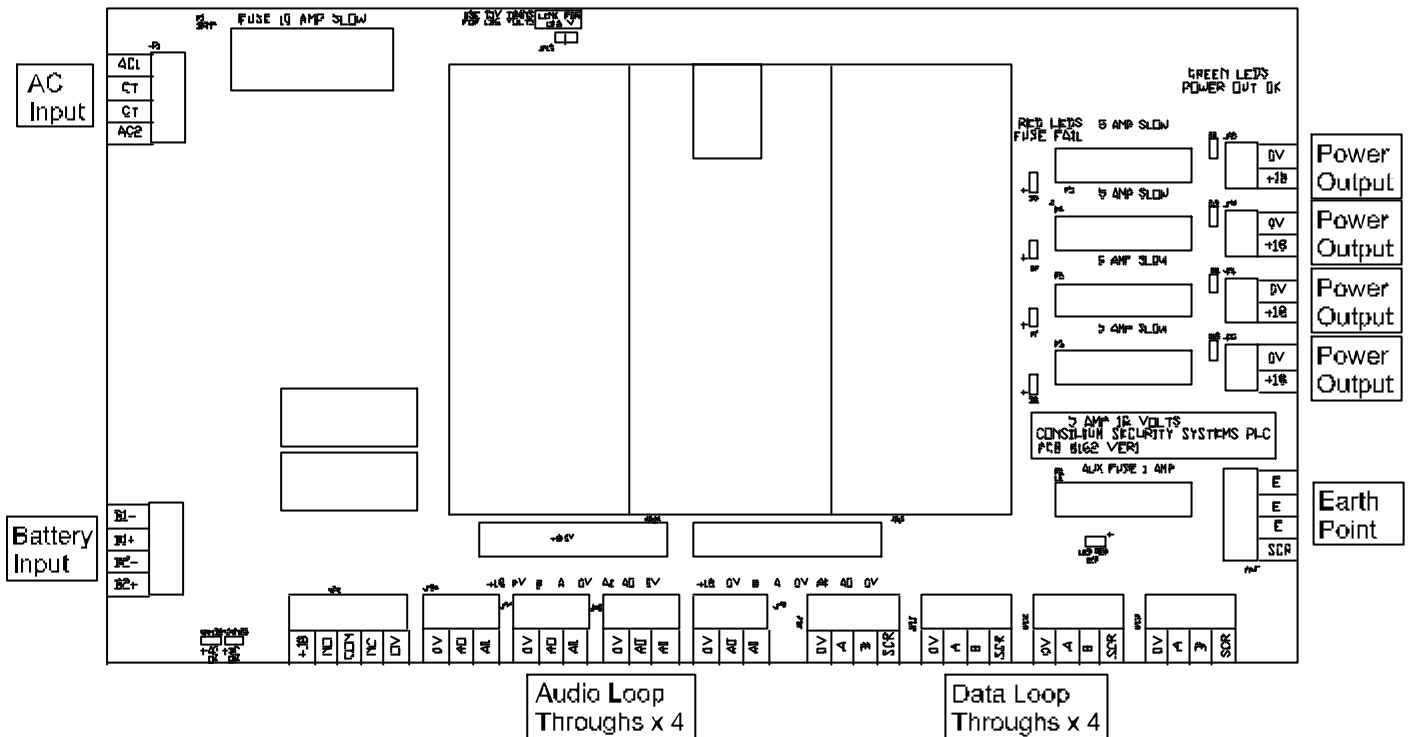

The input is from a 22-0-22 mains transformer and is normally supplied pre-wired

Battery back up is provided by 2x12 volt batteries for the 18 volt version. Battery current rating depends on the system specification, and charging and changeover to standby is automatic. Indication of power OK is indicated by a green LED.

The battery is protected against deep discharge which causes generally irrecoverable damage to the batteries and therefore when the battery voltage falls below a pre-defined level then the battery is disconnected until the mains power has been restored. Re-charging is then automatic.

Battery charge and autonomy times will depend on the size of batteries fitted, the standard charging rate being approximately 1amp per 10 hours.

Where an installation requires more than 5 amps, then fit 1 or more additional power supplies as required. Common the 0v connection between the supplies but DO NOT common the +18 volt outputs as the load will not be automatically shared between the supplies and 1 supply will overload.

The power supply PCB also provides loop through points for the data and audio connections. Many installations focus the wiring on the electrical intake, where the power supply is often installed, and hence the digital decoder cables and the entrance panel cables will be brought back to this intake. The power supply provides a series of connectors for terminating these cables in a tidy manner.

If the cables are terminated at the power unit, then two test connectors become available on the power supply which provide a useful point to connect test equipment, and for programming up the system. The second connection provides for connection of a concierge control panel. These two connectors are identical in function and wiring, and have 18 volts separately fused available on them.

The power supply is protected against short circuits and overload both electronically and by fuses. Two additional input fuses are fitted, rated at 10 amps slow blow. It would be very rare for these fuses to fail, and repeated failures would suggest either a very large overload, or a fault in the power supply.

Where screened cables are used, and the cables are brought back to the power supply, a connector is provided for terminating the screens. This connector has no electrical connection to any other part of the power supply and merely an 'anchor' point for the screens. One terminal of this connector should be connected to mains earth. The data loop through connectors have provision for terminating the screen, and this is connected on the PCB to the earth and screen connector.

### 3.4 Dwelling Handset Options

Each dwelling can be installed with a telephone handset equipped with:

- a) A door release button.
- b) An optional privacy button which prevents the handset being called from the entrance panel until either a pre determined time has elapsed (adjustable on the main Decoder Circuit board see, Hardware Configuration or within the software configuration see advanced programming), or the occupant switches the facility off (AT1131/CN).
- c) An optional indicator LED which indicates the privacy facility has been activated (AT1131/CNI).
- d) An optional door monitoring LED which flashes on door lock release and stays on permanently whilst the door is open to indicate door release and door open, respectively (AT1131/CNID).

A full detailed technical specification of each item and detailed ordering information is included within Appendix 7.

## 4. INSTALLATION

### 4.1 Installing the Cases

The installer should decide on the optimum position to site the system devices taking into account the following factors:

- (i) The security of the system.
- (ii) Minimising the lengths of cable runs (especially CW1308).
- (iii) Accessibility for service.
- (iv) IEE Regulations: 16th Edition.

An assessment of the cable requirements to the main circuit board should be made (i.e., how many dwelling handsets are to be connected) and, taking this into account, the cases should be drilled for the cable access and the appropriate glands fitted prior to installing the Circuit boards.

### 4.2 Installation guidelines

The Citadel range is designed for easy installation and on site configuration. The power supply contains loop through connectors for both data and audio, providing a convenient termination and test point.

The whole system is tied together with a simple data network, which uses RS485, bandwidth limited to conform with EMC requirements. Each board on the network is essentially connected with a 3 wire data link, two wires of power, and 3 wires of audio. Some devices that will be made available in the future will not require audio, in which case a 4 wire connection will suffice.

Each board or device connected to the network has a unique address set on a DIP switch. The decoders always occupy addresses 1-32, and the entrance panels 33-96. This is not of great concern to the installer, simply number the decoders 1-16, and the entrance panels in a similar manner, i.e. 1-64. The software takes care of the offsets.

## 5. WIRING THE SYSTEM

The success of an installation largely depends on the correct wire type being used, and the installation work being carried out by a competent person. It is the installers responsibility to ensure that the correct wiring type is used and Planit Security Contracts Limited will not be liable for any failure of the system where any deviation of these instructions has been made. Please ensure you comply in particular with the earthing requirements as this is an important consideration in respect of the systems EMC compliance.

### 5.1 General Wiring & Cable Requirements

The following wiring details and cable specifications relate to installing the Citadel series without any provision for spare conductors. Please note that many clients specify that installations must provide for a given percentage of spare conductors to allow for expansion of the system at a later date.

It is the responsibility of the installer to check what the requirements of any particular installation are, and to increase the number of conductors in the cables accordingly.

## 5.2 Wiring Overview

For successful installation the following procedures should be carried out closely, using the correct cables as specified. The schematic below shows how the component parts of a system are connected.

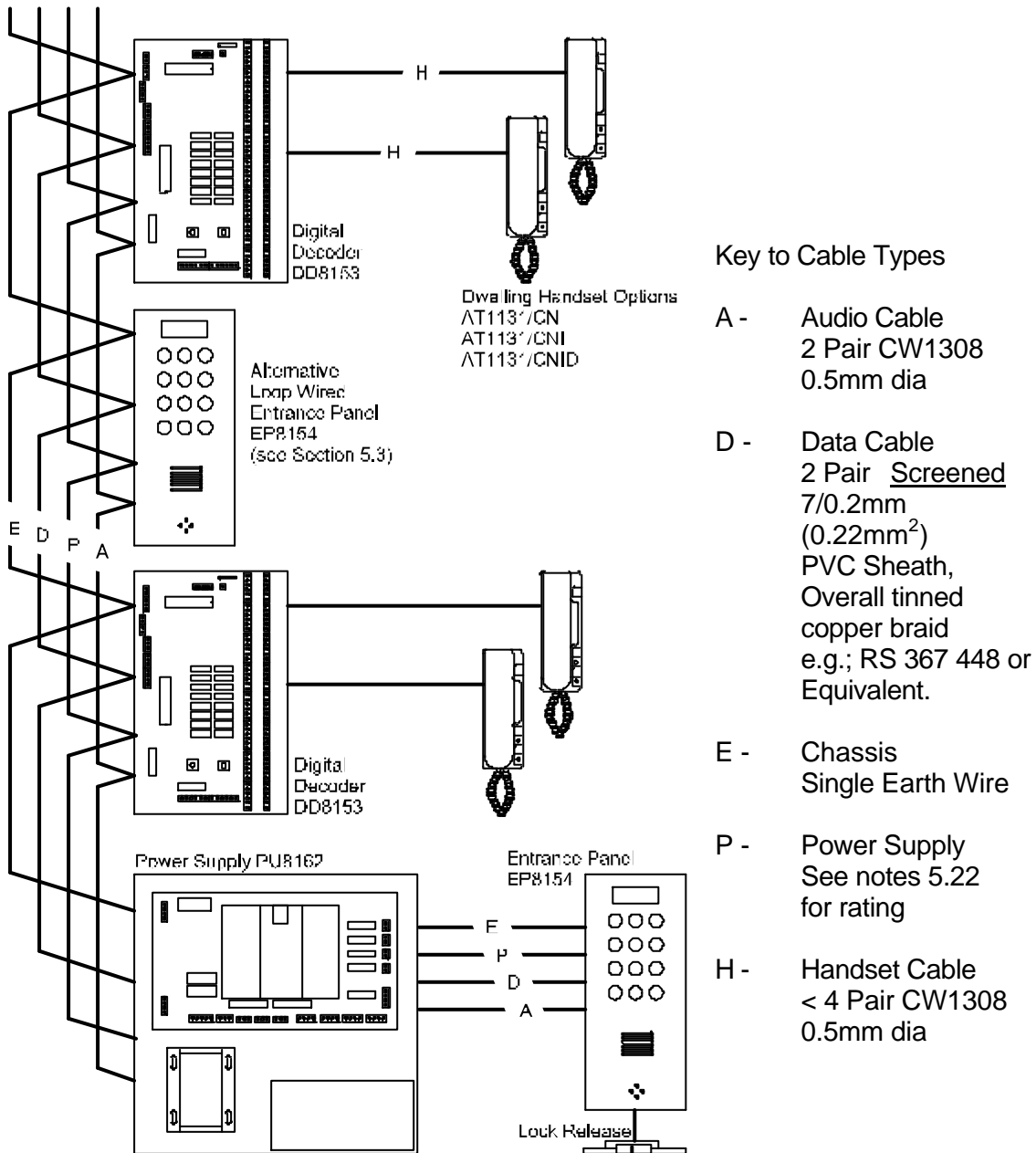

For Citadel Video refer to appendix 11

### 5.2.1 Data and Audio Cabling

The following guide lines should be followed:

For dwelling telephone handsets use 4 pair CW1308 cable, or if local specifications will allow it, 3 pair. Where privacy and door alarms are not required, a two pair cable will often suffice. Cable lengths to the dwellings are not critical, and up to 200 metres does not represent any problem. Extension telephones are simply wired in parallel with existing telephone. Privacy switching is synchronised between extension telephones by software and requires no additional wiring. A maximum of 3 telephones may be connected to one channel. Power consumption should be taken into consideration.

All boards on the system are daisy chained using a 3 wire data link, a 3 wire audio link, and a 2 wire power link. Where local regulations demand a fully star wired system, isolation boards can be supplied. The diagram shows the data and audio cabling using the loop through connections. This is not essential as all cables can be terminated to suit the installation, but using the power supply loop through facilities provided assists in ensuring the installation is tidy and understandable.

The data link cable must be screened, and the screens should be linked through at the decoders using the connectors provided, and connected to Earth at the power supply, again using the connectors provided. The RS485 link is slew limited, and does not generate a significant amount of interference (within EMC limits) but the use of screened cable is good practice and avoids any potential problems with external sources of electrical interference. Again, cable length is not critical, and the RS485 system can handle a maximum cable length of approximately 2000 metres.

The audio link again should be screened when installed within electrically harsh environments, this avoids potential problems of external pick up of interference, and where audio units are installed in lifts etc., using the dwelling interface on the decoder, these cables must also be screened. (Lifts can generate lots of hum and interference).

### 5.2.2 Power Cabling

Many installation problems can be attributed to poor or inadequately specified power feeds. Power Feeds require some thought. The Digital Decoders and the entrance panels require a minimum voltage of 15 V dc. Remember when designing cable runs to the entrance panel to allow sufficient cable capacity for the lock release consumption.

A large number of installation problems originate from incorrect power cabling. The inherent design of the Citadel range greatly simplifies the cable calculations.

Entrance panels are heavy users of power, due to the presence of lock releases and should be cabled on an individual basis back to the power supply.

#### *Decoder Power Cabling*

Each decoder takes 0.375 amps maximum, including the LED's. The minimum voltage that must be present at each decoder is 15 volts, and with a power supply of 18 volts, this means a maximum voltage loss of 3 volts.

The first step is to calculate the total decoder power consumption which is simply the number of decoders multiplied by 0.375.

The next stage is to ascertain the total cable run to the decoders. In most cases this will be a daisy chain. Where decoders are wired in groups back to the power supply, then the calculation should be made for each group of decoders.

### Cable Losses

These can be ascertained from the manufacturers data books, but the following table covers the most common types of cable. This table gives the LOOP resistance of the cable per 100 metres. A 1 Ω loop resistance means that for a 1 amp current, 100 metres of cable will drop 1 volt as defined by ohms law  $V=IR$ .

Cable Type	CW1308	7/0.2mm	1.0mm	1.5mm	2.5mm	4.0mm	6.0mm	10.0mm
Ω Per 100	20	9.5	3	2.5	1.2	0.75	0.5	0.3
Ω Per Metre	0.2	0.095	0.03	0.025	0.012	0.0075	0.005	0.003

### Example

8 decoders with an 80 metre cable run.

$$\text{Total Current} \quad 8 \times 0.375 \quad = \quad 3 \text{ Amps.}$$

The maximum cable resistance from ohms law ( our maximum loss is 3.0 volts )

$$R = V, I \quad 1.0W = 3 \text{ volts, } 3.0 \text{ Amps}$$

To do the optimum calculation using the resistance per metre figure:

$$\begin{aligned} 2.5 \text{ mm cable} \quad 80 \times 0.012 &= 0.96 \text{ W.} \\ 1.5 \text{ mm cable} \quad 80 \times 0.025 &= 2.00 \text{ W} \end{aligned}$$

Hence a 2.5mm cable is fine, a 1.5mm cable is under-rated.

The current consumption of almost any door entry system is dominated by the locks and the phone LED's. A typical phone with both LED's ON will consume about 16 ma.

Hence 16 phones in privacy with the door led on will consume 256 ma. The control electronics use very little power, i.e. approximately 20ma. Note that the system power consumption is constant irrespective of the number of LED's on or off due to the design characteristics of the decoder.

### Entrance Panel Power Cabling

Entrance panels are dealt with in the same manner. The display board with 8888 displayed, the worst case condition uses about 400ma. Again this consumption is dominated by the LED display.

The lock release is the major contributing factor, and depending on the lock release configuration, can draw up to 1 amp. In most cases the guideline figure of 1.5 amps per panel is more than adequate, BUT CHECK YOUR LOCK RELEASES (A list of typical lock release currents is detailed in appendix 5), to ensure this figure is correct. The calculation for panel cabling is carried in the same manner as for decoders.

### *Cabling to the Lock release*

Often, space is restricted within the door frame, and the smallest possible cable are often desirable. The entrance panel generates exactly 12.00 volts at 1 amp for the lock release. Allow maximum loss to the lock release of 0.5 volts.

For a 1amp lock release circuit then the maximum resistance is:

$$R = V, A \quad \text{i.e.} \quad 0.5, 1 = 0.5 W.$$

For a ½ amp lock release circuit the maximum resistance is:

$$R = V, A \quad \text{i.e.} \quad 1.0, 1.0 = 1.0 W.$$

Using 1308 cable then for 1 amp lock release the maximum cable length is 2.5 metres, and for a ½ amp lock release, 5 metres. For most applications then, you can get away with 1308 for ½ amp lock releases, and some cases this will also work for 1 amp lock releases. For safety, use 1.00 mm cable.

Again, site conditions dictate that you should always check this calculation. A common cause of lock release unreliability is low lock voltage, and we cannot repeat it enough, do NOT forget to fit diodes on each lock, observing the correct polarity.

A list of typical lock release currents is detailed in Appendix 5

### *Cable Optimisation*

The above calculations will produce a correct result and greatly enhance installation reliability. Since volts drop is proportional to current consumption, some careful mathematics will show that you can reduce the cable thickness as you proceed further from the power supply. We strongly suggest you do not attempt to do this, as the calculations are very complicated.

As can be seen from the wiring diagrams, connecting up is simple a matter of wiring terminal to terminal, all terminals that are linked together carry a common designation, i.e., the data link is wired up by daisy chaining the connections marked A, B, and 0v to all boards. Likewise, the audio is wired by connecting all the AO, AI, and 0v connections in a daisy chain. The power to entrance panels can also be connected in this daisy chain method, however to assist with power isolation in the cases of severe vandalism, each panel should be provided with its own supply cable.

### ***DO NOT common up the 0v connection for the audio with that of the data link.***

For a new installation, separate cables for data and audio are mandatory. However, the communications protocol used is designed to be electrically quiet, and it is possible within certain limits to use a common cable for both audio and data. When this type of installation is required a twisted pair should be used for the audio, and a separate twisted pair for the data, there is NO advantage in doubling up pairs, and in the case of the data link, it can degrade the communications to double up the cables.

### 5.2.3 Earthing Requirements

Ensure earthing wire (cable e) has continuity between metal cases, case lids and metal chassis of entrance panel(s). Ensure that the Data cable screening is earthed only at the Power supply unit. This is facilitated by the use of the loop through connectors and ensuring that the Main PSU Circuit Board is earthed via terminal jp14. Note; Do Not common up the 0v connection for the audio with that of the data link. Use separate cables if possible

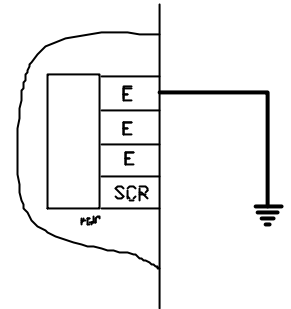

### 5.3 Data Connections

\*Refer to the note regarding spare conductors for system expansion in section 5.1 and the specific cable requirements in section 5.21.

The data connections are effectively loop wired using the following terminals.

Please note; no allowance has been made within the entrance panel for termination of the cable screen for the data cable. **No termination should be made.**

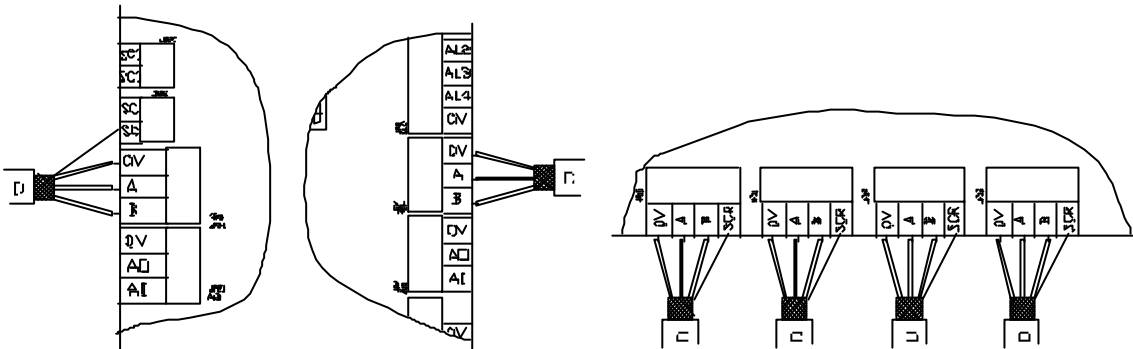

DD8153  
Digital Decoder

EP8154  
Entrance Panel  
Controller Card

PU8162  
Power supply  
Loop Through Facility  
(see "earth" note)

The following

colour code should be adopted;

Ov Blue and Black - twisted pair

A Red } Twisted Pair  
B Black }

For Citadel Video refer to appendix 11

### 5.4 Audio Connections

\*Refer to the note regarding spare conductors for system expansion in section 5.1 and the specific cable requirements in section 5.21.

The audio connections are effectively loop wired using the following terminals.

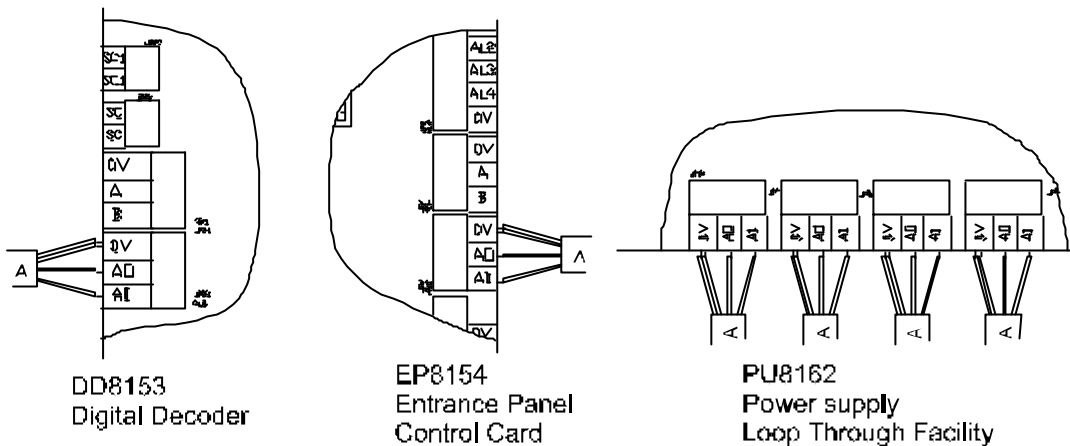

The following colour code should be adopted;

- Ov White of Orange and White of Blue
- AO Orange of White
- AI Blue of White

For Citadel Video refer to appendix 11

## 5.5 Power Supply Connections

\*Refer to the note regarding spare conductors for system expansion in section 5.1 and the specific cable requirements in section 5.22.

The Power connections are effectively Star and Loop wired using the 0v and +18v outputs from the system power supply (PU8162).

The following colour code should be adopted;

- +ve Red
- ve Black

For Citadel Video refer to appendix 11

## 5.6 Dwelling Handsets

A maximum of three handsets can be fitted to any one extension.

Check which handsets are being installed and which features require connection to the main circuit board.

The diagram below shows a schematic of the connection of the handset to the Digital Decoder circuit board.

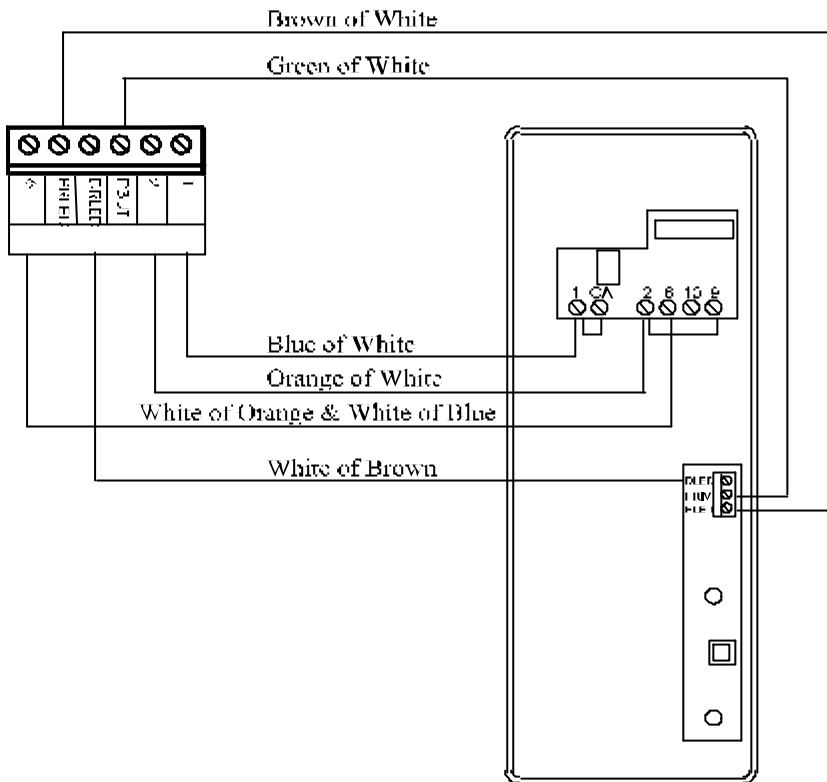

Handset AT1131  
Features: Standard handset. Note links between, 1 & CA and, 2 & 9.

Handset AT1131/CN  
Features: Standard handset with privacy button.

Handset AT1131/CNI  
Features: Standard handset with Privacy button plus LED indication.

Handset AT1131/CNID  
Features: Standard handset with Privacy button plus LED indication and Door Monitoring LED.

Diagram showing schematic of handset to Digital Decoder circuit board connection.

Note: Connection of, DRLED, PBUT and PRLED (Digital Decoder) to DLED, PRIV and PLED (handset) only applicable when fitting a handset equipped with the relevant Privacy/Indicator and Door Monitoring features.

**Cable Information**

Each dwelling handset requires connection via a CW1308, eight wire (four pair) cable. The following connections from the main circuit board to handset are required: 1 ( Spk), 2 (Mic), PBUT, DRLED, PRLED and 6 (0V).

Connection to the handset should be made as follows:

Digital Decoder Connection	Connecting Wire	Handset Connection
1	Blue of White	1
2	Orange of White	2
PBUT	Green of White	PRIV
DRLED	White of Brown	DLED
PRLED	Brown of White	PLED
6	White of Orange and White of blue	6

Please note the doubling up of the 0V terminals. This is advisable as the additional screening of the cable provided by the two wires reduces noise on the line and can improve voice quality.

The wiring details and cable specifications relate to installing the Citadel series without any provisions for spare conductors. Many clients specify that installations must provide for a given percentage of spare conductors to allow for expansion of the system at a later date. It is the responsibility of the installer to check

what the requirements of any particular installation are, and increase the number of conductors in the cables accordingly.

For Citadel Video refer to appendix 11

## 5.7 Door Lock Releases

Door lock releases fall into two distinct types: Fail Safe (fail unlocked), and Fail Secure (fail locked). It is absolutely vital that the installer identifies which is the type of release specified to be fitted, and ensures that the correct type is installed with the correct method of connection to the system.

**Important Note:** The maximum current that the system can provide through any one lock circuit is 1 amp. It is the installers responsibility to ensure that this limit is not exceeded. Currents in excess of this can lead to damage of the system and possible malfunction. Planit Security Contracts Limited will not be responsible for damage caused where these limits have not been adhered to.

A Fail Safe (fail unlocked) door lock release requires power to be applied to it continuously for the door to remain locked. Should power be removed, either as a result of a power cut or from a dwelling occupant pressing the lock release button on a handset, then the lock will release.

A Fail Secure (fail locked) door lock release will deny access in its passive state, i.e., it requires power to be applied to enable access. A power cut will therefore result in the door remaining in the locked, or secure state.

### 5.7.1 Cable Information

The cable to each door lock release should be two core with a diameter of at least 1mm on each conductor. To ensure reliable operation, the cable run between lock release and main circuit board should take into account the need to minimise any voltage drop. The maximum voltage drop allowed on this circuit is 1V.

### 5.7.2 Fail Safe (fail unlocked) Lock Release Connection

For the fitting of Fail Safe type door lock releases, the connection of the lock release to the main circuit board should be made as follows:

NB: Conductors to door lock release must be a minimum of 1mm diameter.

The diode is to protect the main circuit board from back EMF on lock release. Use an 1N4001 diode or equivalent. It should be fitted as close to the lock as possible, not at the circuit board terminals. Ensure correct polarity of diode.

Please note that the NC and N/O contacts on the relay refer to the relay in the powered up state, i.e., when power is applied to the main circuit board.

In the non powered state the contacts are reversed. In practice, this has no effect on the wiring details, but acts as an extra safety feature in that a system failure or malfunction would switch off power to a Fail Safe lock release, allowing access.

Diagram of fail safe lock release connections to 12V and N/C terminals, also showing link between 0V and common terminals and orientation of protecting diode.

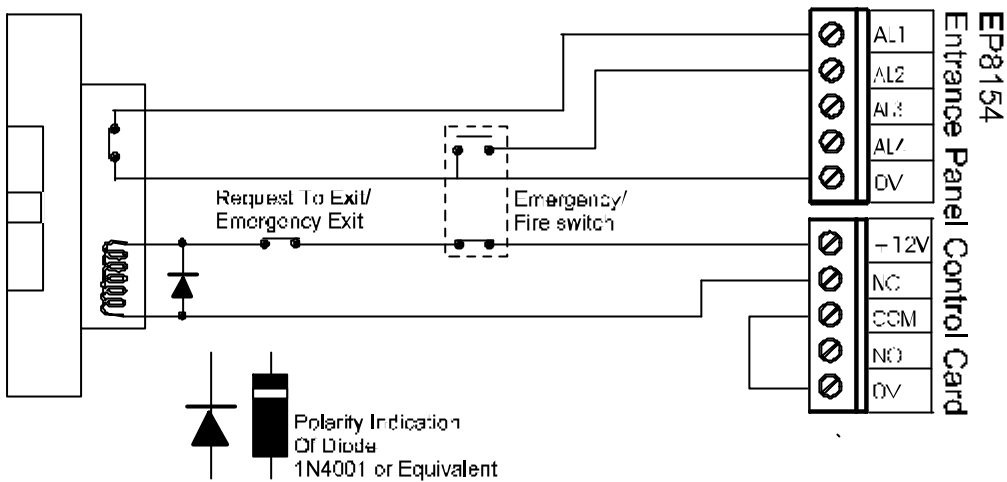

In addition to the wiring layout shown in the diagram, the relay contacts N/C, Common and N/O can be used as clean switching contacts, to a maximum rating of 30V DC @ 2A.

NB: Conductors to door lock release must be a minimum of 1mm diameter.

## 5.8 Panel Amplifier

Panel Amplifier (Speaker and Microphone)

The connection of the Panel Amplifier involves four terminals from the amplifier unit and the EP8154 Entrance panel control card (jp8); 1= (Mic), 2= (Spk), +=(12V) and -= (0V).

Note: Connection 1A is not used in this installation.

Diagram of panel amplifier showing wiring connections.

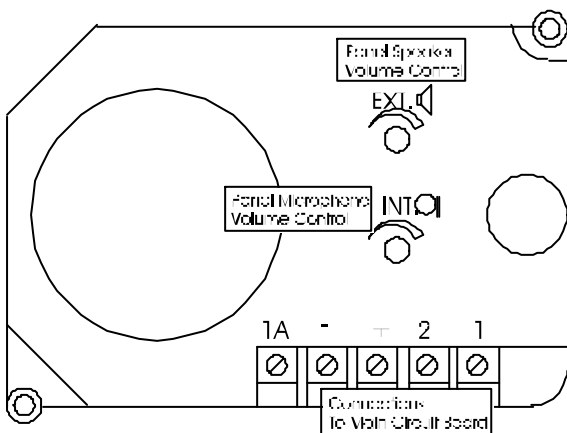

## 5.9 Request To Exit Switches (RTE)

The normally closed (N/C), RTE switch should be wired in series with the lock on the 12V supply. As shown in the door lock wiring diagram, these switches are specified as single pole. Activation of the switch will also activate the door release.

## 5.10 Door Monitoring Contacts

The door monitoring facility enables occupants in every connected dwelling to be aware when the door lock release has been activated (flashing red LED on handsets), and when the door has actually been opened (red LED steadies). The monitoring system works on a normally closed (N/C) or normally open (N/O) contact system. On activation of a door release command from a dwelling handset, the door monitoring LED will flash. The contact type is configured with the software set-up procedures.

When the door is opened and the switch contacts broken (or made), the monitoring LED on all dwelling handsets will remain continuously illuminated indicating that the building is insecure until the door is closed and the contacts revert back to their N/C (or N/O) state. Refer to the diagrams Re: Fail Safe connections for Door Monitoring wiring connections.

## 5.11 Strobe Connection

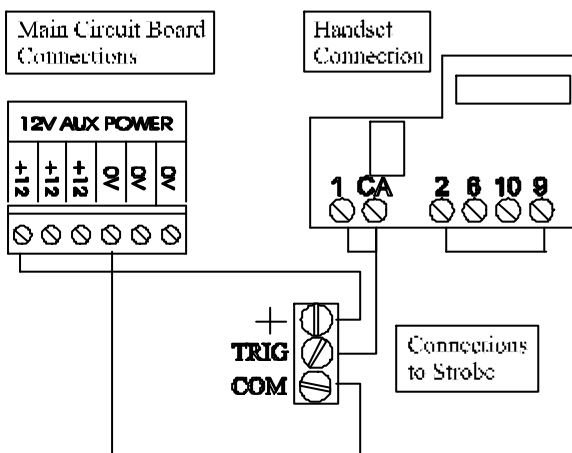

Additional equipment such as a strobe to alert deaf or the hard of hearing residents can be installed. In this instance power can be supplied from the Auxiliary power contacts on the main circuit board, with a trigger from the CA Connection on the handset (see diagram).

Diagram showing connections for strobe.

## 5.12 Battery Back Up

Type: Sealed lead acid  
 Voltage: 24V Total (2 x 12 V units)  
 Capacity: the capacity for the batteries should be based upon the consumption of the system as follows;  
 $(\text{No of Hubs} \times 0.275) + (\text{No of E/Panels} \times 0.40) + (\text{No of Locks} \times \text{Lock current})$

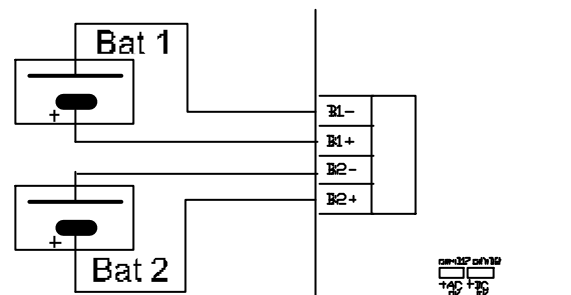

The back up battery should be connected to the main circuit board via the contacts marked.

Ensure correct polarity, i.e., [B1 + to + and B1 - to - B2],[ + to + and B2 - to -]. See diagram above.

## 6. HARDWARE CONFIGURATION

### 6.1 System Addressing

Each Device connected to the network requires a unique address to identify itself to other devices on the network, e.g., Entrance Panels, Digital Decoders. This is set utilising the address select Dip switch located on the device. The address is defined in binary coded format, however to ease the setting the board legend is labelled in decimal. Switch on the relevant combination of switches to set the address.

In the example shown (S3, entrance panel) switches 1 - 4 set the address and in this case is set to 10.

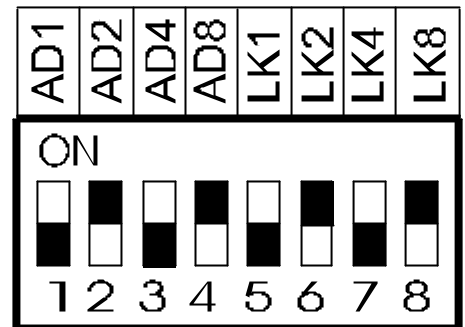

Note address offsets are carried out within the software, hence decoders are numbered 1 - 16 and panels 1 - 64.

### 6.2 Door Tone Volume Controls

The system uses a reassurance tone from the panel which confirms to the caller that the required dwelling is being contacted following the pressing of the appropriate button on the entrance panel. A further tone is produced by the panel on the door lock being released, to indicate to the caller that access is now possible. the entrance panel tone volume can be set by the relevant rotary potentiometer control R27. Turn clockwise to increase volume, anti-clockwise to decrease.

### 6.3 Microphone & Loudspeaker Volume Control

On answering a call, the dwelling occupant can have a full duplex conversation with the caller (full secrecy of speech means that other dwelling handsets cannot be used to listen to this conversation). The volume of this conversation can be set by adjustment of the Microphone and Loudspeaker volume controls in the entrance panel amplifier

Volume is increased by turning each potentiometer in a clockwise direction, volume reduced in an anti-clockwise direction (see details within section 5.8).

### 6.4 Privacy Function Timer

The Citadel range allows for each handset user to disable and restore the call function from their handset. An LED illuminates when the privacy function facility is in use as a reminder to the handset user that they are not accessible (Note: This function is only applicable on handsets equipped with a privacy function).

In addition, the system also incorporates a timer which will restore the call function to any handset after the privacy function has been in operation for a predetermined time. This prevents a handset user from accidentally forgetting that the call facility has been disabled and remaining permanently unobtainable.

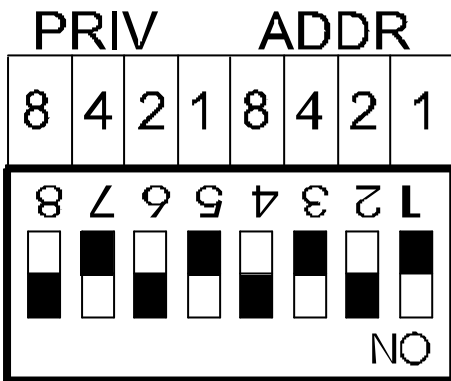

The system *default* timer is set on the main circuit board by means of four DIL switches. It is possible to override this timer setting utilising the configuration software either on a system wide basis or on an individual dwelling basis, please see configuration instructions.

Note that in the diagram the switches are coloured white. The privacy function utilises switches 5,6,7 and 8.

Time is selectable as building blocks of 1, 2, 4 and 8 hours. This makes a total allowed time for the Privacy function of, 1+2+4+8=15 hours. Switches are set by moving them towards the ON inscription on the DIL switch itself.

In the diagram the time is set at ten hours (2+8 hours selected).

If all switches are set off, i.e., no time selected, then the privacy function will be controlled directly via the software or by the users handset. On revision 1 of the decoder software this feature did not work correctly. You could set the privacy but not clear it. This has been corrected on Revision 1.1.

## 6.5 Disable Lock Release Sensing

The lock sensing capability is responsible for the timed access following the initial release of the door lock.

When the circuit is broken, by a RTE momentary switch for example, a current sensing circuit monitors the current drop in the lock circuit, and then automatically withholds power to this circuit for the set lock release time. However, in installations where the system has to control several locks or a high power locking mechanism.(e.g., a barrier gate), the Citadel main circuit board may not have sufficient power, and a secondary, relay powered lock supply would be required. The Citadel main circuit board would then only be required to control the comparatively very low current of the switching relay.

In this example, if the lock circuit from the main circuit board is only driving a relay then the current is likely to be reduced to below the sensing threshold of the lock sensing circuit (< ~10mA). The possible effect of this would be that the door release timer would be permanently on and the door would remain in an unsecured state. This problem can be overcome by increasing the load by wiring a 600R ¼ watt resistor in parallel with the relay.

The disable lock sensing facility allows the current sensing circuit to be disabled. This is achieved by installing a link over the two pins marked, JP11 on the entrance panel circuit board.

Please Note: If this facility is disabled, the access will only be available for the duration the momentary switch is depressed, i.e., a short time period. It is important, therefore that the circuit directly powering the locks has its own lock timing circuit to allow a timed access on lock release.

## 6.6 Functional Panel Selection

Setting switch 4 dil S2 on the entrance panel control card (8154) selects the operational mode for the entrance panel as digital (default) or functional. Select mode as **off** for digital operation and **on** for functional. When in functional mode the 62 possible button inputs are allocated dwelling numbers;

- 1 - 62 allocated to dwelling call buttons.
- 63 allocated to the Trades button.
- 64 allocated to an optional cancel button.

Please note that this function should be used with care as further programming may not be possible with the resulting limited number of buttons.

For a full diagram of the connection matrix for the buttons please refer to Appendix 6.

## 6.7 Alarms

Door alarms are reported to all telephones on the system, and normally illuminate the door open LED on the telephone. When the lock release is operated the door open LED on the telephone flashes for about 4 seconds irrespective of the lock release period programmed into the entrance panel. If the door alarm was active when the lock release was operated then the telephone LED would be ON. It will change to flashing for 4 seconds and then switch OFF the LED. After about 30 seconds the door state will be updated by the system and reflect the true state of the door alarm input.

On multiple door systems, the telephone LED will reflect the cumulative state of all the doors, with an open door taking priority. i.e., any door open will illuminate the telephone LED's. All doors must be closed for the LED to be OFF.

The system updates the telephone door LED's every 30 seconds to one minute. This ensures that if the network was disconnected for any reason, and updates were not transmitted during the disconnection, then within 1 minute of the network being re-connected the system will reflect the true state of the doors.

If your system does not require door open LEDs, then you can leave the entrance panel alarm inputs open circuit, and program the panel for the alarm contact to be active when the contact is closed.

## 6.8 Fire Switch

When the fire switch is not wired to the 8154 as an alarm input, then the AL2 connector on the alarm input connector of the 8154 entrance panel board should be wired to 0v. Otherwise erroneous fire switch alarms will be reported.

## 7. PROGRAMMING THE SYSTEM

### 7.1 Software Configuration Overview

The software configuration menu is divided into two sections dealing with start up “get you going” options and advanced system engineering and customisation options respectively. This section (7) deals exclusively with those menu items that are necessary to get your system running simply and successfully. We have described in detail setting the time to demonstrate the programming operation and general syntax and protocols necessary.

All the software configuration is held in non-volatile memory, with a manufacturers predicted retention of 100 years. This memory contains the dwelling configurations, lock release timings, Menu Commands Restore, and other site specific information. All these configurations can be modified on site using a standard entrance panel without recourse to off site programming facilities.

We recommend the use of the programming data sheet included at the end of this section (7.5) to note all standard configured information, and that the data sheet or a copy be left with the equipment for future system maintenance assistance.

The system can be configured as a functional system, in which case the entrance panel may not have a display, nor sufficient buttons to carry out this work. (see section 6.6) In general the defaults will suffice for a functional system, and where they need changing, you will need access to a digital panel to carry out this work.

### 7.2 Software configuration Guide

#### 7.2.1 Setting the Defaults

The first operation in setting up a new system is to install the default values.

Default parameters are set up by entrance panel DIP switch S3 switch 8 ON and pressing reset. The standard default dwelling tables will be copied to working memory along with default trade times and access codes.

Remember to set DIP switch 8 **OFF** before attempting any custom configuration otherwise the next time the board is reset or powered down all the new configuration will be overwritten with the defaults.

Use this operation with great care. It will overwrite any current information in the system, including the dwelling configuration. This could take some time to re-enter. You would normally only use this function with a new system.

The Defaults Routine runs as follows and will take 2 -3 minutes

- Resets system memory (count 8192 bytes)
- Establish default Dwelling tables
- Establish default system settings
- Establish default ring levels
- Establish default ring period
- Establish default privacy timers

A full default settings list is included in Appendix 10

#### 7.2.2 Gaining Access to the Configuration Program

Access to this program is protected from unauthorised use with two interdependent features.

- 1) to enter programming mode you must first gain access to the circuit board fitted to the back of the panel and press the programming button. This button press is remembered for 6 minutes, during which time you must also enter a password number.

The panel will emit a tone on correct activation of this switch. See adjacent diagram

- 2) Enter the pass number 04368. On pressing the zero, the display will change to ----, and the remaining 4 digits will not be displayed. Press the CALL button, and the display will change to PROG for two seconds, and then the display will clear except for 4 dots at the bottom of the display, indicating programming mode.

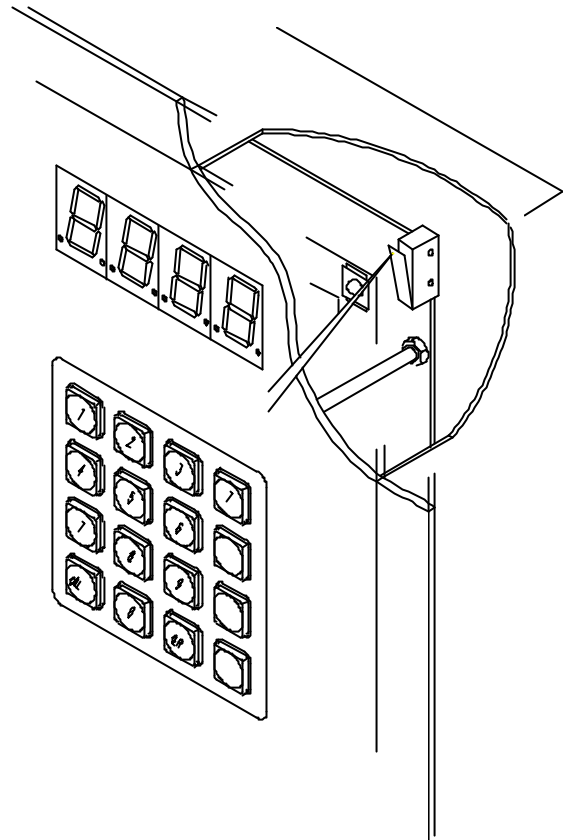

If following the above operation the message Err appears there could be several reasons:

- 1) You did not press the programming button first, or more than 6 minutes elapsed before you entered the pass number.
- 2) You incorrectly entered the pass number.
- 3) The pass number cannot be changed.

All system configuration variables are selected by keying a 2 digit number when in program mode.

### 7.3 Start up Menu Code Listing

System Settings	51	Set Time	24hr Format
	52	Set Date	Day of week
			S1 M2 T3 W4 T5 F6 S7
			DD c MM c YYYY
Access Settings	60	Set Trades	trade number nn
			start time/stop time
			DOW = 1234567
			must have 7 entries 0 for no!
	61	Sync Trades	
	62	Clear Trades	Password protected
	63	Set Coded 1	4 digits (leading 0 added auto.)
			Time Profile = trade number
			or 00 for constant
	64	Set Coded 2	"
	65	Set Coded 3	"
	66	Set Coded 4	"
	67	Set Coded 5	"
	68	Sync Coded	
	69	Clear Coded	Password protected
Dwelling Config	70	Set Dwelling Config	Line number (L) = 001 - 199
			dwelling number = nnnn
			Digital Decoder/port = xxyy
	71	Set Dwelling Protect	Protects dwelling configuration
			Password protected
	72	Set Dwelling Unprotect	Unprotects dwelling configuration
			and restores header
			Password Protected
	73	Sync Dwelling Configuration	
	74	Load Defaults	Password protected
	75	Delete Database	Password protected
Door settings	80	Set Lock Time	1 - 99 in sec's (default 8)
Master Settings	99	Exit Menu	Restores normal operation

## 7.4 Software Configuration Instructions

### 7.4.1 Synchronisation Functions

It is possible for a system with more than one panel to synchronise many of the configuration settings across the network to all panels. This is achieved by keying the synchronisation function code for each relevant menu function. Please note that utilising this option will update the full configuration for that item on all other panels on the network thereby overwriting any existing configuration.

Standard Menu options	61	Synchronise Trades access configuration
	68	Synchronise coded access configuration
	73	Synchronise dwelling configuration
Advance Menu options	55	Synchronise BST/GMT configuration

The following configuration items are included within the “synchronise dwelling option” and is synchronised by line (database location number)

- dwelling number
- Digital Decoder / channel number
- network number
- Individual ring period (if set)
- Individual ring level (if set)
- Individual privacy time (if set)

Please note: When activating the synchronise dwelling configuration function in particular, please remember that all other entrance panels on the network will have their dwelling configurations overwritten. This can be avoided by selecting the “set dwelling protect” function on the panel(s) that does not require the update information. We would also recommend that before you synchronise the system in this way you first check the protect status of all panels to be in the correct mode and that those panel correctly programmed also have their configuration backed up to local memory (see function 90/91) so that in the event of any programming errors the original configuration can be restored.

This situation is only a problem on sites that have multiple panels and the multiple panels each have unique configurations.

### 7.4.2 Clear Functions

The system provides several clear functions to enable the user to reset the configuration of a certain function. The following clear functions are included

Standard Menu options	62	Clear Trades access configuration
	69	Clear coded access configuration
	75	Delete dwelling Database configuration

If you wish to clear these elements network wide;

- 1) Clear the element at the panel being programmed
- 2) Synchronise the function (see above)

All clear commands require the system password to activate the function as a safeguard for the data.

### 7.4.3 Individual Function Details

#### 51 Set Time

In order to illustrate the system programming operation we will program the system to display the time, and change the time to the correct time in detail, all operational elements for programming the system are similar to this operation.

In standby mode the system can be programmed to display the current time, or just a blank display. For most systems the display will be blank.

The first operation is to enable time display (note this is an advanced programme setting):

From the programming 'prompt' i.e. .... key 54 and press call.

The display should now either show a flashing 1 or a flashing 0. If the display already shows a 1 then it is programmed to display the time, but we will pretend it was not! The flashing display indicates the value displayed can be changed by overkeying, if it is not flashing then it cannot be changed.

Now key in 1, to set the display time function active, and then press call. The 1 should now stop flashing indicating the value has been programmed.

Pressing call again should now set the system back to the programming prompt. Note that the CANCEL button will always force the system to the programming prompt, abandoning the current operation.

#### 51 Set the time:

From the programming 'prompt' i.e. .... key 51 and press call.

The current time will displayed flashing.

This time can be now overkeyed will a new time, all times are entered in 24 hour mode. Note that all 4 digits are always required, i.e. 7:00 am would be keyed as 0700. Pressing call will now enter this time into memory. Please note that any changes to the time are broadcast network wide. i.e., any device connected to the network that is 'time aware' will automatically be updated with the new time.

With one or two exceptions noted under the specific functions, the programming of a function obeys the following general format assuming you are in program mode:

- 1) Enter the two digit number to access the feature to be programmed.
- 2) The current value will be displayed, flashing, indicating it can be overkeyed.
- 3) Key in the new value.
- 4) Press call and the new programmed value will be displayed, not flashing.
- 5) Press call again and you will be returned to the basic programming mode (level 0) ready to enter a new feature number.

If you merely wish to check a value proceed as above, but when the flashing value appears, simply press call and the old value will be retained, and this value will be displayed not flashing.

At any time you can abandon programming a value by pressing cancel which will return you to the basic programming mode. (level 0)

To restore the system to normal operation, key 99 and press call when in level 0.

## 52 *Setting the Date*

As with time setting, any changes to the date will be broadcast network wide. The time setting program is an exception to the standard syntax in that having changed an entry the program proceeds to the next value without displaying the programmed value in the non flashing mode.

Date is set as follows:

Key 52 to enter the program. The first entry is the day of week, not to be confused with the date. The day of week is the day number, where Sunday is normally 1. This entry is important when trade times are programmed, as day exclusion depends on the day of week being set correctly.

The sequence is as follows:

Day of week	S=1, M=2, T=3, W=4, T=5, F=6, S=7
Date	dd
Month	mm
Year	yyyy

Each entry can be overwritten when displayed 'flashing'.

## 60 *Trade Times*

The standard system allows for 10 trade times for each door. Each trade time is programmable for specific days of the week if required. Each door on a multiple door system can have a unique set of trade times.

On most systems, it is sufficient to enter the times at 1 door only, and then use program 61 to synchronise the trade time across all panels.

The trade times can be programmed to active only on certain days of the week. Assuming Sunday is day 1 then programming the number 1234567 will mean that that particular trade time is active for days 1 to 7 inclusive.

Similarly keying 0234560 would mean that this trade time is active from Monday to Friday (23456) and not Saturday or Sunday. (00) Note that 7 digits must always be keyed, 0 means inactive, and any other digit 1-7 means active.

Trade times are entered using program number 60.

- 1) Enter the program number and the display will show t001, indicating trade time 1.
- 2) Press call and the trade start time will displayed 'flashing'.
- 3) Overwrite the start time if required and press call.
- 4) The new programmed value will be displayed, not flashing.
- 5) Press call and the end time will be displayed 'flashing'.
- 6) Overwrite the new number if required and press call.
- 7) The new programmed value will be displayed not flashing.
- 8) Press call and the first 4 DAYS will be shown.
- 9) Overwrite all 7 days as required, note the display will sideways scroll digits off the left hand side, but they are NOT forgotten.
- 10) Press call and the first 4 digits programmed will be displayed.
- 11) Press call again and the second 3 digits will be displayed.
- 12) Press call again and the display will show the next trade time number, i.e. t002.

13) Repeat as required and press cancel to exit to programming level 0.

The system also provides trades times 11 - 20, however these are allocated to time profiles for coded access numbers and will not be activated by the trades button when in an active period.

### *63 - 67 Set Coded Access*

The standard system contains five 4 digit coded access numbers which can be set by the user, or by the installer.

These coded access numbers can be given time profiles, i.e., they only work at certain times on certain days of the week in a similar manner to trade times, and in some cases can easily substitute for the trade button facility, with more security.

Coded access numbers are changed by using programs 63 to 67, where each program number gives access to different coded number. If a time profile is required the time profile is defined using the trade times program, but using trade time 11 to 20. The trade times of 11 upwards are specifically reserved for coded access time profiles. Each coded access number can have a different time profile, or they can all have the same time profile, or combinations thereof.

Coded access numbers need only be set on 1 panel, and then using the program number 68 they can be synchronised across all the panels on the system.

- 1) Enter the program number (e.g.; 63) and the display will show nnnn, indicating the coded access number, 'flashing'.
- 3) Overwrite the new number if required and press call.
- 4) The new programmed value will be displayed, not flashing.
- 5) Press call and a two digit number will be displayed 'flashing'. This equates to the time profile to be attached to the coded access number.
- 6) Overwrite the new number if required and press call.
- 7) The new programmed value will be displayed not flashing.
- 8) Repeat as required for access numbers 64 - 67.

### *70 Dwelling Configuration*

Each Digital Decoder can support 16 dwellings, and there can be up to 16 Digital Decoders on a local system. The software and hardware design caters for networked systems, and in this case each system, or group of Digital Decoders has a unique network number. For a single standalone system this number is normally 1.

The dwelling configuration defines where each dwelling is connected on the hardware. When you key a dwelling number at the entrance panel, the software refers to this table to find the physical location of that dwelling. This information comprises the NET number, which would normally be 1 for a standalone system, and all dwellings in the system would normally have the same network number, the Digital Decoder number to which that dwelling is connected, and the port, or line number on that that particular Digital Decoder to which the dwelling is wired.

When the system defaults were installed, a 'get you going' table was installed which defines the dwelling configuration as follows:

Dwelling 0001 connected to Net 1 Digital Decoder 1 Port 1  
to  
Dwelling 0016 connected to Net 1 Digital Decoder 1 Port 16

Dwelling 0017 connected to Net 1 Digital Decoder 2 Port 1  
to  
Dwelling 0032 connected to Net 1 Digital Decoder 2 Port 16

Dwelling 0033 connected to Net 1 Digital Decoder 3 Port 1  
to  
Dwelling 0048 connected to Net 1 Digital Decoder 3 Port 16...

This is repeated up to dwelling 128 on Digital Decoder 8 port 16.

There is no restriction on the ordering of this table, although it does make future examination easier if the table is in numeric dwelling order. If you are lucky, the site follows the order of the defaults, but in most cases this table will need to re-entered from the beginning.

Having got your system going with the defaults, if the table needs to be re-entered then this is most easily carried by first resetting the default table to zero, i.e., no entries.

The tables can be completely reset by using the programming command 74 "load default tables", which will prompt you to enter the system password, '04368' to confirm the operation. Resetting will take a few seconds, during which time you will notice the display counting up the number of entries being reset. On completion you can now commence setting up the system from the installation documentation.

If it is necessary to amend only a few individual dwelling settings, it is simpler to utilise the "jump to dwelling" command. Please see test and engineering facilities section 8.4.

The dwelling configuration table has 256 entries as standard, allowing for up to 256 dwellings. As an option this can be increased to 512 dwellings or more.

The table is numbered from 1 to 256, and any dwelling can be placed in any position, but as previously mentioned, it is easier to work with system if they are kept in order.

To program the dwellings proceed as follows:

- 1) Key in the program number 70.
- 2) The system will now display L001, the first table entry.
- 3) Press call.
- 4) The dwelling number stored in that entry will be displayed (If the tables have been reset, then 0000. (flashing)
- 5) Overwrite the current dwelling number with the new number, all 4 digits, i.e. dwelling 1 is keyed as 0001. And press call. The dwelling number programmed will now be displayed not flashing.
- 6) Press call and the Digital Decoder and the port will be displayed flashing, (0000 if a reset system).
- 7) Key in the Digital Decoder number that the dwelling is connected to, followed by the port number. i.e., for a dwelling connected to Digital Decoder 3 port 4, key 0304. Note the mandatory use of 4 digits.
- 8) Press call and the display will stop flashing, displaying the programmed value.
- 9) Press call again and the program will advance to the next line to programmed, i.e., the display will show L002. Repeat as required.

Within the dwelling configuration menu the standard display sequence is as follows;

L001	Database location (line number)
0001	Dwelling number (the dialled number)
0101	System location reference (Digital Decoder Number and Port Number)

.....

Continued

However, it is possible to set the individual privacy times, ring tone levels and ring tone period within this same menu item if the advanced function "individual dwelling function adjustment" is enabled, (see menu item 92 in advanced programming features). Therefore if the menu continues as follows;

10	Ring Period
08	Ring Level
00	Privacy time

then either step through these options, amend these options carefully, or disable the advanced facilities option (key 92 and select off 00). For full details on the programming of these options please see the advance programming details.

When all the entries have been programmed, then you can exit the program by pressing cancel.

Note if you modify the default tables (i.e. you do not reset the tables to zero) and leave in dwellings that do not exist on your system, the entrance panel will still recognise them and attempt to call that number. If the hardware does not exist the message ER1 or No Such Flat (LCD) will appear. We suggest you do not leave invalid entries in the tables as this can confuse both the users and Service Engineers in the future.

Where the system has multiple panels, and all the panels have the same configuration, then it is only necessary to program 1 panel and then this configuration can be broadcast to all other panels on the network using the programming command 73 synchronise dwelling configuration. Please note that when activating the synchronise dwelling configuration function all other entrance panels on the network will have their dwelling configurations overwritten. This can be avoided by selecting the "set dwelling protect" function on the panel(s) that does not require the update information. We would also recommend that before you synchronise the system in this way you first check the protection status of all panels to be in the correct mode and that those panel correctly programmed also have their configuration backed up to local memory (see function 90/91) so that in the event of any programming errors the original configuration can be restored.

Once programmed, the dwelling tables can be protected, i.e., converted to read only, by entering program number 71. This will enable the tables to be scanned (a common requirement both at install and by maintenance engineers) but not changed.

Normal editing can be restored by keying program number 72 (Set Dwelling Unprotect).

If you wish to amend or edit one particular dwelling reference use the "jump to flat function" - see test facilities section 8.4.

### 80 Set Lock Time

The lock time (release period) can be reset from the default 8 seconds using this function. Key "80" then enter the required lock period in seconds.

## 7.5 Programming Data Sheet

Please note: Completion of this data sheet does not replace, negate or modify any contractual or legal obligations of the installer, including compliance with specific installation specifications or requirements as detailed in the Installers Handbook supplied with this product. This information should be kept with the system to allow future maintenance.

CLIENT \_\_\_\_\_

SITE ADDRESS \_\_\_\_\_

HUB No:		HUB No:		HUB No:		HUB No:		HUB No:		HUB No:	
PORT	DWELLING	PORT	DWELLING	PORT	DWELLING	PORT	DWELLING	PORT	DWELLING	PORT	DWELLING
1		1		1		1		1		1	
2		2		2		2		2		2	
3		3		3		3		3		3	
4		4		4		4		4		4	
5		5		5		5		5		5	
6		6		6		6		6		6	
7		7		7		7		7		7	
8		8		8		8		8		8	
9		9		9		9		9		9	
10		10		10		10		10		10	
11		11		11		11		11		11	
12		12		12		12		12		12	
13		13		13		13		13		13	
14		14		14		14		14		14	
15		15		15		15		15		15	
16		16		16		16		16		16	

Panel Address (s)											
Trades 1 on	:	Trades 2 on	:	Trades 3 on	:	Trades 4 on	:				
Trades 1 off	:	Trades 2 off	:	Trades 3 off	:	Trades 4 off	:				
Trades 1 DOW		Trades 2 DOW		Trades 3 DOW		Trades 4 DOW					
Code 1	0	Code 2	0	Code 3	0	Code 4	0	Code 5	0		
Code 1 profile		Code 2 profile		Code 3 profile		Code 4 profile		Code 5 profile			
Password		Lock Period		Fire Lock Period							

Commissioning Engineer \_\_\_\_\_ Signature \_\_\_\_\_

Commissioning Company \_\_\_\_\_ Date \_\_\_\_\_

## 8. ADVANCED PROGRAMMING FUNCTIONS

### 8.1 Advanced Programming Functions Overview

The advanced programming functions enable you to further customise various elements of the system and allows certain test routines to be initiated. Adjustment of the settings within this menu structure could severely effect the operation of the system so please ensure you note and document any changes prior to their implementation.

### 8.2 Advanced Menu Code Listing

System Settings	53	Set GMT/BST	
	54	Set Time Display	0 off 1 on (takes <10secs to update)
	55	Sync GMT/BST	
Dwelling Config	76	Jump to Dwelling	dwelling number = nnnn
	77	Jump to Port	Digital Decoder/port = xxyy
	78	Set Net Number	Default 1 Otherwise = nn
Door settings	81	Door Alarm Contact Mode (AL1)	00 = N/O & 01 = N/C
	82	Fire Switch Contact Mode (AL2)	00 = N/O & 01 = N/C
	83	Fire Reporting Global/Local	00 = no & 01 = yes (for programming panel to rx)
	84	Fire unlock Global/Local	00 = no & 01 = yes
	85	Fire lock Period	1 - 9999 in sec's (default = 20)
	86	Set Privacy Reporting	00 = no & 01 = yes
	87	Test Dwelling	Enter Dwelling number reports status
Master Settings	90	Back up Configuration	
	91	Restore Configuration	Password protected
	92	Enable Individual dwelling function adjustment	
	94	Set Master Ring Level	1 - 10 Default 8
	95	Set Master Ring Period	10 - 999 secs Default 30
	96	Enable Door Forced report	
	97	Enable/Disable Lock Period Truncate (Door alarm)	0 or 1
	98	Set Master Privacy time	
	99	Exit Menu	Restores normal operation

## 8.3 Advanced Software Configuration Instructions

### 53 *Set GMT/BST*

The system includes an integral facility for automatic time switches from BST (British Summer Time) to GMT (Greenwich Mean Time) default settings have been pre-programmed for the years for years 1996 - 2001 with 1 hour forward and lag period set. (note this defaults to nearest Sunday)

It is possible, using this function, to reprogram the dates or further enter new dates and also change the forward / lag time period.

Key "53" the software forces the year as the menu item - 1996 etc.

- |     |              |                       |
|-----|--------------|-----------------------|
| 1)  | Prog bst-d   | forward day           |
| 2)  | Set bst-d    |                       |
| 3)  | Prog bst-m   | forward month         |
| 4)  | Set bst-m    |                       |
| 5)  | Prog advance | advance time in hours |
| 6)  | Set advance  |                       |
| 7)  | Prog gmt-d   | back day              |
| 8)  | Set gmt-d    |                       |
| 9)  | Prog gmt-m   | back month            |
| 10) | Set gmt-m    |                       |
| 11) | Prog back    | lag time in hours     |
| 12) | set back     |                       |

### 78 *Set Network Number*

The network number is used on multiple systems, normally with a concierge panel. Each group of Digital Decoders, comprising a system, is assigned a unique network number, normally starting at 1. To set the network number, enter program number "78", and overwrite the flashing digits with the appropriate network number. The software will automatically update all dwellings in the configuration with the new number, and this will take a few seconds, during which time the display will count up, indicating the update progress.

### 81 *Door Contact Mode*

The door monitoring contact input on the entrance panel (labelled AL1) allows either normally open or normally closed input monitoring. Use menu item "81" to set the contact mode where

- |   |                 |                   |
|---|-----------------|-------------------|
| 0 | Normally open   |                   |
| 1 | Normally closed | (default setting) |

### 82 *Fire Contact Mode*

The emergency fire switch input (designated as AL2) has a similar Normally open / normally closed option. Use menu item "82" to set the contact mode where

- |   |                 |                   |
|---|-----------------|-------------------|
| 0 | Normally open   |                   |
| 1 | Normally closed | (default setting) |

### 83 *Fire Reporting Global/Local*

When the fire switch is operated, the entrance panel will generate a timed bck release as defined in the system set-up parameters. This period would default to 20 seconds. The message fire will be displayed on the entrance panel. The "Fire" message is broadcast network wide.

It is possible to configure the panel to display the fire message if broadcast from another panel, this is activated by function call "83"

Select 0 to ignore fire broadcast messages from other panels.  
Select 1 to display Fire on broadcast receipts

### 84 *Fire Unlock Global/Local*

Similarly to the above function the entrance panel can be configured that when the message is broadcast from the other panel(s), it will automatically unlock the door for the fire switch period. This is activated by function call 84.

Select 0 to ignore fire broadcast messages from other panels.  
Select 1 to release the door on broadcast receipts

### 85 *Fire Lock Time*

The lock time activated by a Fire Switch or network trigger (release period) can be reset from the default 20 seconds using this function. Key "85" then enter the required Fire lock period in seconds.

### 86 *Set Privacy Reporting*

When a dwelling is called that the handset privacy function is active, the entrance panel can display the status. It is possible to configure the panel to display the status of the privacy switch, this is activated by function call "86"

Select 0 to ignore the privacy switch (note; this does not override the privacy function).  
Select 1 to display Privacy selected when called (PRIV)

### 90 *Backup / 91 Restore*

This command backs up and restores all dwelling table information including dwelling numbers, their locations, their ring period and levels, and the privacy time (count should be 3072 bytes)

### 92 *Enable Individual Dwelling function adjustment*

This function enables and disables the option to individually update the dwelling functions and facilities. It has the effective function of switching on the programming options for privacy time, ring period and ring level within the dwelling configuration tables. The following function order is applied with programming ranges and factors;

ring period	10 - 196	seconds
ring level	1 - 10	level
privacy time	1 - 15	hours

For full details on the dwelling configuration details please see menu item 70 within the standard programming instructions.

#### 94 *Set Master Ring Level*

The master ring level (dwelling handset call tone) can be reset from its default value of 8 in a factor of 1 - 10 using this function.

- 1) Select the program number 94 to define the ring level, range is 1 to 10. All dwellings will now be updated with this new value.

#### 95 *Set Master Ring Period*

The master ring period (dwelling handset call tone duration) can be reset from its default value of 30 seconds to a value in the range 10 - 196 seconds using this function.

- 1) Select the program number 95 to define the ring level, range is 10 - 196. All dwellings will now be updated with this new value.

#### 96 *Enable Door Forced report*

The door monitoring function can be configured to provide an alarm output upon illegal use of the door (i.e., not a valid lock release). This is configured using function 96.

Select 0 to disable the door forced report function

Select 1 to enable the door forced function, this causes a signal to be generated at alarm output 2 for driving a sounder or similar.

#### 97 *Enable lock period truncate*

In the systems default state the lock timer is truncated (reset) once the door is detected as physically open via the door contact monitoring circuit. This function can be disabled by using function call "97"

Select 0 to disable the lock release period truncate function

Select 1 to enable the lock release period truncate function (door release time resets when door is opened)

#### 98 *Set Master Privacy Time*

Privacy times for the handset may be set by three methods;

Hardware DIL switch settings - see section 6.3

if no other software privacy timer settings are configured, the system will use the default hardware setting.

Master Software Setting

Function call "98" followed by a privacy time (in Hours) will update all dwelling tables to a common privacy period.

Individual Software setting See function "92" above.

## 8.4 Test Functions

The software structure provides several test and engineering functions accessible from the entrance panel programming mode

76	Jump to dwelling	Enter Dwelling number	Returns Digital Decoder and Port address
77	Jump to port	Enter Digital Decoder and Port Address	Returns dwelling number

Having accessed the required dwelling / port it is possible to amend the configuration for that dwelling where the values are flashing. For full details please refer to menu call function 70 and related items for full details.

87 Test Dwelling enter "Dwelling number"

The system will report the dwelling handset status and report the following codes;

GOOD for handset OK  
PRIV for privacy on  
HOOK for Handset off Hook  
OPEN no Handset connected or speaker o/c

## 9. FAULT FINDING THE SYSTEM

This sections provides more detailed information on some of the features of the Citadel range and advice on fault finding.

### 9.1 Data network

The data network used is RS485, at 9600 baud. It uses fully formed packets with a 16 bit check sum, and as a result is very robust. Signalling is two wire, bi-directional, and the data cannot be easily identified on a normal "ascii" terminal. All data transmissions are fully CRC checked, and if there is a transmission error, the sending terminal will retry 5 times for a connection (please see appendix 3 for entrance panel error message definitions).

Fault finding in most cases is straightforward and does not require any special test equipment. A communications problem will generally manifest itself as the inability to call a flat, or group of flats associated with a particular decoder or group of decoders.

### *Procedure*

First check that the wiring is correct! i.e., all data A terminals are connected together, and likewise all data B terminals and the 0v connection.

Check that the decoders have the correct address switch settings, and that no two decoders have the same address.

Check that the power supply voltage to each decoder is > 15 volts and < 18 Volts dc.

Check with the system connected that the A wire is at 4.2 volts +- 0.5 volts dc, with respect to 0v.

Check with the system connected that the B wire is at 0.3 volts +- 0.5 volts dc, with respect to 0v.

The A wire should be more positive than the B wire by at least 0.5 volts dc.

This check proves that the network is basically healthy with no short circuits on the data bus B wire. Since the A wire is substantially at 0v in the idle condition its voltage reading is not conclusive. As a quick check for the A wire, short the A wire to the B wire, ( this does no harm ) and check the voltage with respect to 0v. It should be about 2 volts +- 0.5 volts dc. If it is lower than 1.00 volt, then a short circuit to 0v is suggested. IT DOES NOT FIND OPEN CIRCUITS.

If the above test shows a problem, then it should be isolated in the normal manner by progressive disconnection.

Open circuits are a little harder to test for as the data bus will often show correct voltage readings at most points throughout the data bus, as each device connected to the data bus has its own built in bias circuitry.

To find open circuits, disconnect the data bus from the device or devices that you are unable to communicate with, and measure the data bus voltages as described above on the CABLE side of the connector. Isolate using normal fault finding practice.

## **9.2 Audio Network**

The audio network is a daisy chain between all the entrance panels and decoders, along with any other audio devices that might be connected. With the system idle, there should be no voltage present on either the AI or the AO wire with respect to 0v, and an  $\Omega$  check from each to 0v should show open circuit.

Shorts to 0v should be located in the normal manner.

The audio network should be checked for continuity by placing a loop on the AI and AO lines. Again, this will do no harm.

Audio levels are set on the amplifier at each entrance panel, there is NO adjustment on the decoders for audio levels.

## **9.3 Calling Problems**

Network problems normally manifest themselves as the inability to control a device in its entirety. If you cannot call an individual dwelling try the following:

Check that the entrance panel is programmed correctly for that dwelling.

If the call is very faint, then check that the panel has not been programmed for a very low ring level.

Use the phone test facility from any panel to check that the phone is connected see programming function 87 above. This test proves the 0v and SPK wire to the phone, including the speaker in the handset.

If this test shows a problem:

Check the wiring from the decoder to the flat, especially the 0v and SPK wires.

Replace the phone.

Replace the decoder.

It is extremely unlikely that a network problem could prevent an individual phone being called.

### *Answering a Call*

The decoder detects when a handset is picked up, stops the ring, and connects the call. If you cannot answer a call, then check the wiring to the phone, especially the MIC wire and the 0v connection. If this is OK then replace the phone and then the decoder if required.

### *Lock Release*

If the lock release button fails, but speech is OK, then check the following:

Replace the telephone.

Replace the decoder, but this is most unlikely if other phones work.

Check the phone 0v connection and verify the cable length of 200 metres decoder to phone is not exceeded. If the cable length is greater than 200 metres, double up the 0v connection.

Note the following:

If when the lock release is operated and you hear the beep confidence tones in the phone, then the phone and probably the decoder are both OK.

If you hear the lock confidence tones at the panel, then most of the system is working correctly. Suspect the lock, the lock wiring, or the entrance panel PCB.

### *Phone Test*

Most of the functions of the phone can be verified by simply switching privacy on and off. This tests:

The Privacy LED

The microphone wire and 0v

The phone speaker as privacy beeps once for privacy on, and twice for privacy off.

## **9.4 Fuses**

The decoder is fitted with 2 fuses. The line fuse is rated at 2 amps, and should NEVER fail. If this fuse fails then it indicated a circuit board fault, or a severe overload on the auxiliary 12 volt line, along with an incorrect fuse being fitted in the auxiliary 12 volt power feed.

## 10. APPENDIX 1 - FULL PROGRAMMING MENU LISTING

System Settings	51	Set Time	
	52	Set Date	
	53	Set GMT/BST	
	54	Set Time Display	
	55	Sync GMT/BST	
	56	Reserved future use	
	57	Reserved future use	
	58	Reserved future use	
	59	Reserved future use	
Access Settings	60	Set Trades	
	61	Sync Trades	
	62	Clear Trades	
	63	Set Coded 1	
	64	Set Coded 2	
	65	Set Coded 3	
	66	Set Coded 4	
	67	Set Coded 5	
	68	Sync Coded	
	69	Clear Coded	
Dwelling Config	70	Set Dwelling Config	
	71	Set Dwelling Protect	
	72	Set Dwelling Unprotect	
	73	Sync Dwelling Configuration	
	74	Load Defaults	
	75	Delete Database	
	76	Jump to Dwelling	
	77	Jump to Port	
Door settings	78	Set Net Number	
	80	Set Lock Time	
	81	Door Alarm Contact Mode	
	82	Fire Switch Contact Mode	
	83	Fire Reporting	
	84	Fire unlock	
	85	Fire lock Period	
	86	Set Privacy Reporting	
	87	Test Dwelling	
	88	Reserved future use	
Master Settings	89	Reserved future use	
	90	Back up Configuration	
	91	Restore Configuration	
	92	Enable Individual dwelling function adjustment	
	94	Set Master Ring Level	
	95	Set Master Ring Period	
	96	Enable Door Forced report	
	97	Enable/Disable Lock Period truncate	
	98	Set Master Privacy time	
	99	Exit Menu	Restores normal operation

## 11. APPENDIX 2 - SYSTEM DEFAULT SETTINGS

The system default settings when supplied as new or re-initialised are as detailed;

Time	Last Used	
Date	Last Used	
		(or 08:00 on 01.01.96 if the values found by the software are non rational)
GMT/BST	1996 - 2001	Programmed
Time Display	0	
Trades	0	
Coded 1 - 5	0	
Dwelling Configuration	1 - 256	
Set Net Number	1	
Lock Time	8	
Door Alarm Contact Mode	1	
Fire Switch Contact Mode	1	
Fire Reporting	0	
Fire unlock	0	
Fire lock Period	20	
Privacy Reporting	0	
Master Ring Level	8	
Master Ring Period	30	Sec's
Enable Door Forced report	0	
Enable/Disable Lock Period Truncate ( Door alarm )	1	
Set Master Privacy time	0	(note no entry ie 0 results in the default hardware privacy setting being utilised (see section 6.3 for the hardware configuration details)

## 12. APPENDIX 3 - ERROR MESSAGE DEFINITIONS

The system provides various error messages. If you are using a system with the 4 digit 7 segment LED display the following error messages have been applied;

- Err No access e.g. trades not "on"  
invalid access code  
dwelling not in table  
i.e., generally invalid user operation
- Er1 Communications error to selected device suggests cable error or device defective or not present ie: wrong board address etc. e.g. Dwelling number does not exist
- Er2 Communications error - self recovering  
Suggests a transaction in progress on transmitting device i.e. o/p buffer full
- Er5 Telephone handset called is not connected - see dwelling testing
- Er6 No communications when using dwelling test programme

### 13. APPENDIX 4 - DIL SWITCH SETTINGS

Switch ref	Switch No.	Function	Set (Value)
<i>Entrance Panel EP8154</i>			
S2	1	Keypad Select Type	“on” for “Storm” Keypad (and individually wired buttons)
	2	Keypad Select Type	“on” for “Dewhurst” Keypad
	3		
	4	Functional Panel Select	“on” for functional panel
S3	1	Address Select	1
	2	Address Select	2
	3	Address Select	4
	4	Address Select	8
	5		
	6		
	7		
	8	Re-initialise panel	

#### *Digital Decoder DD8153*

S1	1	Privacy Period	1
	2	Privacy Period	2
	3	Privacy Period	4
	4	Privacy Period	8
	5	Address Select	1
	6	Address Select	2
	7	Address Select	4
	8	Address Select	8

### 14. APPENDIX 5 - TYPICAL LOCK RELEASE CURRENTS

The following table illustrates the power consumption of some of the more common lock releases. These figures were derived from bench tests using a 12 volts calibrated power supply using common stock. There may be some variation between samples and these figures are supplied without warranty. You must always check the consumption of the lock releases that you intend to use using the manufacturers supplied data.

Magnalock 32C-12	0.32 mA
Magnalock 62C -12	0.25 mA
LR130M	0.16 mA
LR120M	Not Suitable for 12 Volts DC operation
LR500	0.37 mA
LR650	0.48 mA
LR114	0.20 mA

## 15. APPENDIX 6 - TYPICAL ENTRANCE PANEL KEYBOARD MATRIX INFORMATION

The entrance panel for your system will generally be supplied pre-wired, assembled and tested. However the following matrix information is included for the use of service and maintenance personnel.

Type "Storm" Keypad matrix. Note: most individually wired button panels are configured in this manner.

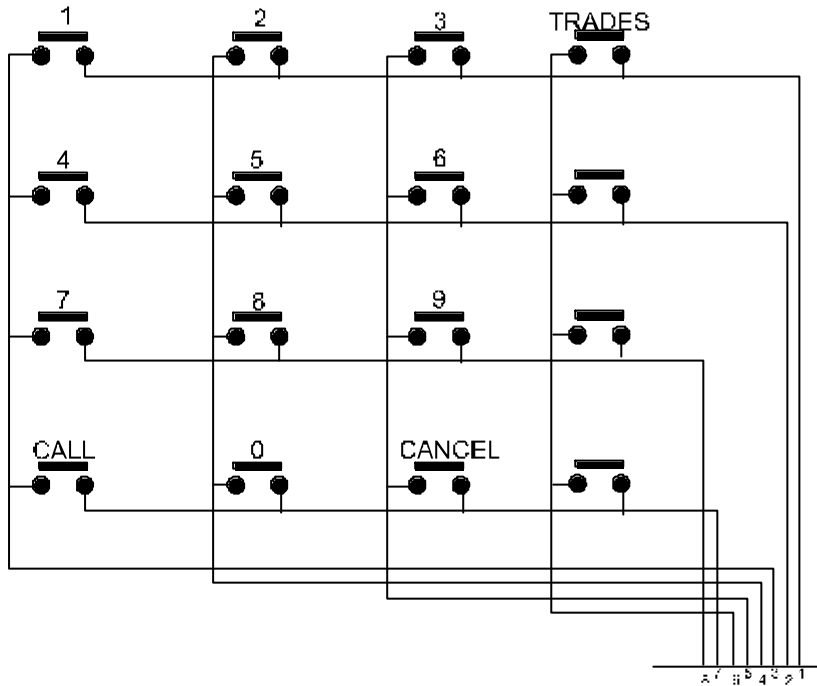

Type "Dewhurst" Keypad Matrix

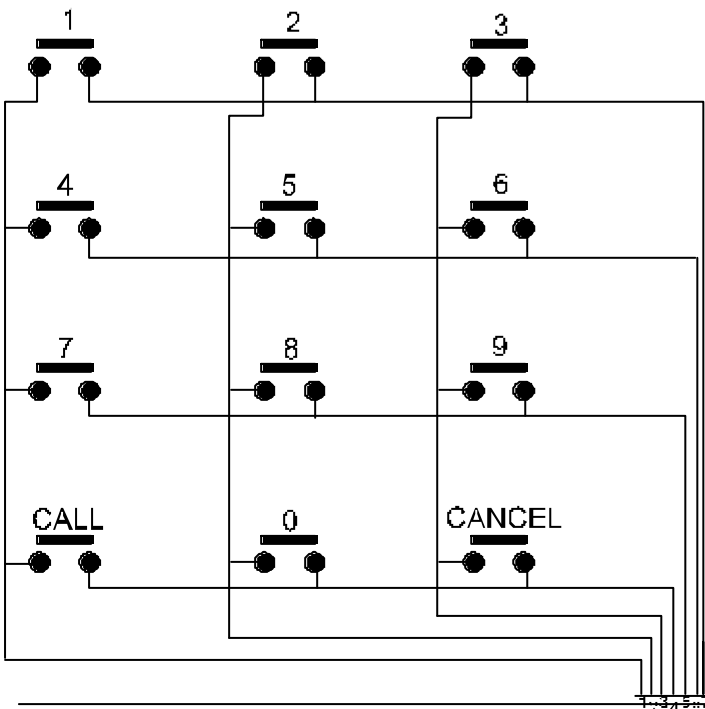

## Appendix 6 - continued

Functional panel button wiring matrix. Note for functional panel operation the “number” designated within the matrix is the effective system number called i.e., dwelling number.

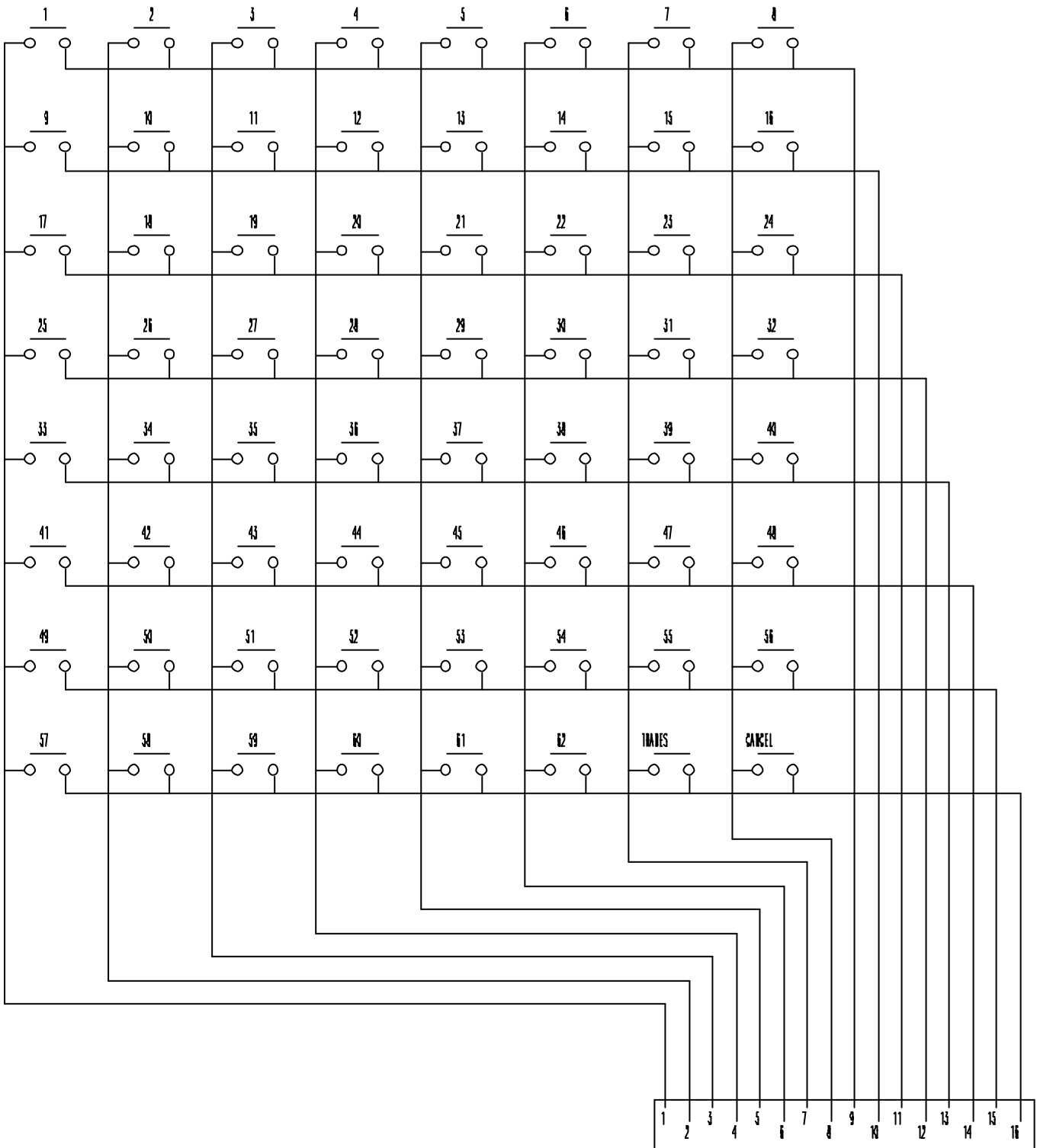

## 16. APPENDIX 7 - SPECIFICATIONS

### 16.1 System

Power requirements: 230V AC, Continuously wired supply.

### 16.2 Digital Decoder

Support 16 dwellings per decoder  
Programmable Privacy Timer  
Fully isolated speech  
Power supply for strobes and sounders  
Variable call tone  
Variable confidence tones  
EMC compliant  
Individually programmable ring level  
Individually programmable ring period

Power Input	15-22 volts
Power Consumption (Max)	
Auxiliary power output	12 volts 500mA max

### 16.3 Entrance Panel

Power Consumption (Max)	( no lock release)
Lock Power	1 amp
Power Input	15-22 volts DC
Lock Release	Relay Switched, fail safe

12 volts at 1 amp available for lock supplies derived from the system 15-22 volt rail. This supply is short circuit protected.

Keypanel Max buttons 64

Keypanel Support Type Vandal Resistant Buttons

Alarm Inputs 2 Designated as follows:  
Alarm 1 Door monitoring  
Alarm 2 Fire switch

Switching threshold 5.00 volt Open circuit voltage 12.00 volts

Alarm outputs

Output 1 Camera switch  
Output 2 Not designated  
Max current sink 250ma each output

A 12 volt and 0v supply is provided with each alarm output. Note that these outputs are NOT isolated, and when used to connect to third party systems, a relay must be used for isolation.

Clock A day/date clock is integral to each panel, self contained battery, life 15 years, date and time is system wide synchronised.

Confidence tones are provided for calling and button push, and a tone level control is provided on the board.

An audio interface connector provides 12 volts, 0 volts, and two speech lines to the amplifier.

20MM 7 segment display as standard

16 Character LCD option

Separate configuration for each panel on multiple panel installations.

Installer configurable.

Integral Trade timer with Day Of Week programming (10 off standard). Default coded as button 'A'

Alpha Numeric Options

Fire Switch Reporting

Global Fire reporting

Global Fire Unlock

Integral GMT/BST switching with programmable forward/lag time.

Timed lock release.

Lock release cancel on door open with 3 second hold Automatic RTE timer. No extra wiring (Patented) single pole RTE buttons provide fire regulations compliant timed lock release

Door open alarm input.

Call progress messages.

Call Confidence tones.

Confidence tone level adjust.

Time Display ( user option )

Coded Access with linked time profiles.

Supplied with a default 'plug and play' configuration.

Busy Indication ( system on multiple panels )

Phone off hook

Individually coded panels for multiple panels with restricted access

## 16.4 Power Supply

5 amps Stabilised at 18.00 volts DC

4 separate fused outputs

4 Power OK output LED's

5 Fuse fail LED's

AC Fail indication LED

AC fail alarm relay

4 Audio loop through connectors

4 Data loop through connectors

1 Overload indication LED

1 Input fuse

Battery charge circuit 24 volt

Cable screen termination

Deep discharge protection

## 16.5 Telephone Handset

High impact white ABS Manufacture

Duplex Speech

Lock Release

Permanent function indication

Door Open LED option (NID)

Privacy Switch option (N, NI, NID) with timed privacy function  
Privacy LED option (NI, NID)  
Privacy set clear confidence tones  
Lock release confidence tone.  
Lock Release confidence flashing LED option (NID)

## 16.6 Citadel Range Ordering Information

The following list is a selection of the extensive product support for the Citadel range. Planit Security Contracts Limited can supply systems tailored to most applications. Please contact us at the number below to discuss your requirements.

<b>Description</b>	<b>Product Code</b>
System Power Supply 18V dc @ 5A In standard case	PU8162/80
Digital Entrance Panel complete with Vandal Resistant individual 20mm dia rotating Buttons Mitred Bezel Back Box Amplifier 7 Segment LED display	EP8154/M/L
16 Channel Digital Decoder in Standard Case	DD8153
12V, 6Ah sealed lead acid battery.	PUA12-6
12V, 15Ah sealed lead acid battery.	PUA12-15
12V, 24Ah sealed lead acid battery.	PUA12-24
Telephone handset with lock release switch.	AT1131
As above with privacy switch.	AT1131/CN
As above with addition of privacy On/Off indicator.	AT1131/CNI
As above with addition of door monitoring indicator.	AT1131/CNID
Strobe lamp for hard of hearing applications. Clear lens.	ATA1121/CLR/C
Extension call tone sounder.	ATA9854/40/C
Entrance panel amplifier	EPA5150/500

Planit Security Contracts Limited also supply a wide range of lock release units to suit this product range in various applications.

For further information please telephone your enquiry to: 0181 502 0136

Or fax your enquiry to us on 0181 508 4670

Please note: Enquiries can only be dealt with during normal working hours.

## 17. APPENDIX 8 - GLOSSARY OF TERMS

**Address;** a unique number assigned to a device that indicates to the rest of the system a messages origin and ensures that only messages destined for the device are received (Addr)

**Coded access;** the ability to enter a normally 5 digit number that if correct releases the door.

**CW1308;** the specification issued for telephone cables, single draw PVC insulated 0.5mm dia twisted paired conductors.

**Database;** the list stored within the software that defines the values and configuration of a system

**Digital Decoder;** a device on a door entry network that receives network messages and decodes them to effectively call a dwelling handset. Generally located within a riser with a series of dwelling handsets connected.

**Digital Entrance Panel;** and entrance panel where the required dwelling number is dialled on a 0 - 9 keypad followed by a call button, usually accompanied by a digital display of some description facilitating the user to check the entered number prior to calling.

**DIL switch;** Dual in Line switch, a bank of switches that are usually used to configure a hardware function e.g. the address.

**Door Monitoring;** the ability to display the status of the door, indicating that the door is open or closed by illuminating an indicator on the telephone handset. Usually red most will flash when the door has been legally released and the steady when the door is actually open.

**Duplex speech;** the ability for the audio circuit to be used in both direction simultaneously ie you can talk and listen at the same time.

**EMC;** Electro magnetic Compatibility all electronic equipment sold must now comply with the European directive on EMC meaning that the equipment does not emit or is not susceptible to Electro magnetic interference. Compliance is indicated by the CE mark

**EMF;** Electro Motive Force, usually experience as back EMF within DC lock releases where the relocking mechanics produces a a high peak of electrical energy that can cause damage to equipment connected to it. Generally eliminated by the connection of a suppressing diode to the lock.

**Fail Safe;** a type of lock release where power is applied to lock, when power is removed (or fails) the lock is released (or safe).

**Fail Secure;** a type of lock release where power is applied to unlock, when power is removed the release remains in its locked state (secure).

**Functional Entrance Panel;** an entrance panel where the operation is functional i.e. 1 button per flat, as an alternative to *digital*.

**Hub;** A digital Decoder

**Isolation;** the ability for an element within a system to be disconnected or damaged without causing adverse affects or damage to the remained of the system.

**LCD;** Liquid crystal display

**LED;** Light emitting diode, a low current, high intensity illuminator

**Network;** a data and/or audio electronic "chain" of devices allowing communications between each device.

**Off Hook;** when the telephone handset is off its cradle.

**Passive Isolation;** a form of isolation that under fault conditions provides full isolation to the device but self recovers upon fault clearance. (Fused systems are not passive)

**PCB;** Printed Circuit Board

**Port;** the channel or connection point for a handset on a digital decoder.

**Privacy;** the ability to switch off a telephone handset and therefore not receive calls.

**Privacy Indicator;** an visual indicator mounted on the telephone handset that is illuminated when the privacy function is selected to indicate that the handset is turned off. Usually green.

**Privacy Timer;** a timer function that when the privacy facility has been selected it is effectively automatically reset after a predetermined period and the handset can now again receive calls

**Protocol;** the type of communications that is used within a network system

**PSU;** Power Supply unit

**Reassurance Tones;** audible tones that are produced by a device to generate reassurance that a button has been pushed or a function is being activated

**RTE;** Request to exit switch / button usually a button located near the inside of a controlled door that when pushed release the door allowing exit.

**Secrecy of speech;** the feature of a system that stops another dwelling listening into the conversation between entrance panel and handset.

**Simplex speech;** the ability for the audio circuit to operate in one direction only. Usually changed by a switch or button, i.e. you can listen but push the button to talk

**Software;** the part of the system that controls the functions. (S/W)

**Strobe;** a xenon beacon generally located with the dwelling that flashes when a call is initiated.

**System busy;** the state adopted by an entrance panel when a system is in use by another panel connected to the systems and the required function cannot be processed.

**Terminal;** a generic name for a device connected to a network

**Time Profile;** a numeric identity applied to a period or time/date window where a function requires to be active e.g. trades period etc.

**Trades Function;** the ability for trades persons to gain access through a controlled door generally by activation of a button. The button is normally only active for predetermined period of the day.



## 18. APPENDIX 9 - COMMISSIONING CHECK SHEET (AUDIO)

Please note: Completion of this check sheet does not replace, negate or modify any contractual or legal obligations of the installer, including compliance with specific installation specifications or requirements as detailed in the Installers Handbook supplied with this product.

CLIENT \_\_\_\_\_

SITE ADDRESS \_\_\_\_\_

NET No						RESIDENT'S SIGNATURE	DATE
HUB No							
PORT	DWELLING	AUDIO	LOCK RELEASE	PRIVACY SWITCH	PRIVACY INDICATOR		
			OPTIONAL				
1							
2							
3							
4							
5							
6							
7							
8							
9							
10							
11							
12							
13							
14							
15							
16							

Commissioning Engineer \_\_\_\_\_

Signature \_\_\_\_\_

Commissioning Company \_\_\_\_\_

Date \_\_\_\_\_

## 19. APPENDIX 10 - DOOR ENTRY TELEPHONE INSTRUCTION LEAFLET

When the door entry telephone rings, pick the handset up. You will be able to speak to your caller in the same way as a normal telephone. To allow your caller to enter, release the door as instructed below.

1) To release the door.

Press the Lock Release button. The red Door Open Indicator will flash to confirm you have released the door for your visitor.

2) Door open indicator.

Upon the door being opened by the visitor, the door open indicator will change from flashing to being constantly illuminated.

The light will stay on until the door has been securely closed.

3) To switch the telephone off.

To switch the telephone off to give privacy from incoming calls, press the Telephone On/Off button. The green Telephone Off indicator will illuminate and the telephone will now be switched off.

No calls can be received when the Telephone Off indicator is illuminated.

4) To switch the telephone back on.

Press the Telephone On/Off button until the Telephone Off indicator extinguishes.

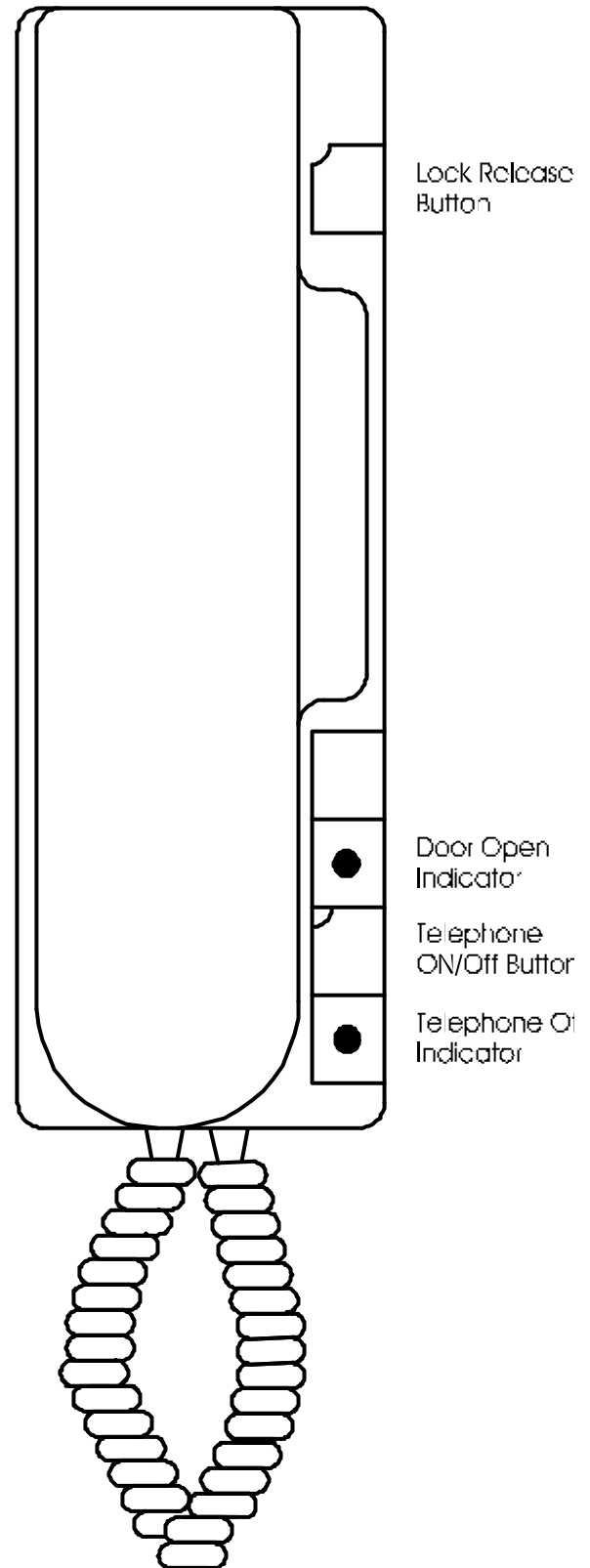

Ten30/nid